

# Hydrostatic Pump Repair

www.hydrostaticpumprepair.net

Phone: 800-361-0028

Email: sales@hydrostatic-transmission.com

**Rexroth**  
Bosch Group

## Axial piston variable pump (A)A4VSO

**RA 92050-A/06.09 1/64**  
Replaces: 09.97

### Data sheet

Series 10, 11 and 30  
Size 40...1000  
Nominal pressure 5100 psi (350 bar)  
Peak pressure 5800 psi (400 bar)  
Open circuit

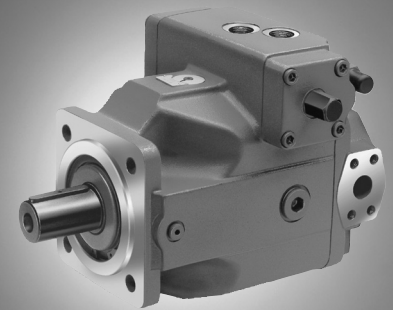

### Contents

Type code for standard program	2
Technical data	5
Characteristics	10
Summary of controls	13
Dimensions, size 40	18
Dimensions, size 71	20
Dimensions, size 125	22
Dimensions, size 180	24
Dimensions, size 250	26
Dimensions, size 355	28
Dimensions, size 500	30
Dimensions, size 750	32
Dimensions, size 1000	36
Through drive	38
Summary mounting options on (A)A4VSO	39
Permissible mass bending moment	40
Dimensions combination pumps	41
Dimensions through drive	43
Installation notes	63
General information	64

### Features

- Axial piston pump in swash plate design for hydrostatic drives in open circuit operation
- The flow is proportional to the input drive speed and displacement. By adjusting the swash plate angle it is possible to infinitely vary the output flow.
- Excellent suction characteristics
- Low noise level
- Long service life
- Modular design
- Short response times
- Wide range of through drive options
- Visual swivel angle indicator
- Optional mounting position
- Operation on HF-fluids under reduced operational data possible
  - A special version is available for operation with HFC-fluid see data sheet RA 92053

For the descriptions of the control devices see the separate RA (RE) data sheets

RE 92056, RA 92060, RA 92064,  
RE 92072, RA 92076, RA 92080, RE 92088

Type code for standard program<sup>1)</sup>

	<b>(A)A4VS</b>		<b>O</b>			/			-						
01	02	03	04	05	06		07	08		09	10	11	12	13	14

Hydraulic fluid / Version		40	71	125	180	250	355	500	750	1000	
01	Mineral oil and HFD-fluids (no code)	●	●	●	●	●	●	●	●	●	
	HFA-, HFB- and HFC-Fluids	●	●	-	-	-	-	●	-	-	E
	For operation on HFC-special performance version see RA 92053 (HFA and HFB see RE 90223)			●	●	●	●				
	High-Speed-Version	-	-	-	-	●	●	●	-	-	H

Axial piston unit		SAE-version	40	71	125	180	250	355	500	750	1000	
02	Swash plate design, variable	SAE-version	●	●	●	●	●	●	-	-	-	AA4VS
		Metric-version	-	-	-	-	-	-	●	●	●	A4VS <sup>2)</sup>

Boost pump (Impeller)		40	71	125	180	250	355	500	750	1000	
03	without boost pump (no code)	●	●	●	●	●	●	●	●	●	
	with boost pump (Impeller) only with port plate 25 (service port connections)	-	-	-	-	-	-	-	●	-	L

Type of operation		O
04	Pump, open circuit	O

Size		40	71	125	180	250	355	500	750	1000	
05	Displacement $V_{g \max}$	in <sup>3</sup> /rev.	2.44	4.33	7.63	10.98	15.26	21.66	30.51	45.76	61.02
		(cm <sup>3</sup> /rev.)	(40)	(71)	(125)	(180)	(250)	(355)	(500)	(750)	(1000)

Control devices		DR	40	71	125	180	250	355	500	750	1000	
06	Pressure control	DR	●	●	●	●	●	●	●	●	●	DR..
	Pressure control for parallel operation (RA 92060)	DP	●	●	●	●	●	●	●	●	●	DP..
	Flow control	FR	●	●	●	●	●	●	-	-	-	FR..
	Pressure and flow control	DFR	●	●	●	●	●	●	-	-	-	DFR..
	Power control with hyperbolic curve (RA 92064)	LR	●	●	●	●	●	●	●	●	●	LR.. <sup>3)</sup>
	Manual control (RE 92072)	MA	●	●	●	●	●	●	●	-	-	MA..
	Electric motor control	EM	●	●	●	●	●	●	●	-	-	EM..
	Hydraulic control, control volume dependent	HM	●	●	●	●	●	●	●	●	●	HM..
	Hydr. control, with servo/proportional valve (RA 92076)	HS	●	●	●	●	●	●	●	●	●	HS.. <sup>3)</sup>
	Electronic control	EO	●	●	●	●	●	●	●	●	●	EO.. <sup>3)</sup>
	Hydraulic control, pilot pressure dependent (RA 92080)	HD	● <sup>4)</sup>	● <sup>4)</sup>	●	●	●	●	●	●	●	HD.. <sup>3)</sup>
	Secondary speed control (RE 92056)	DS1	●	●	●	●	●	●	●	●	○	DS1.. <sup>3)</sup>
	Electro-hydraulic control system DFE1 System solution SYHDFEE (RE 92088) (RE 30035)		●	●	●	●	●	●	-	-	-	DFE1.. <sup>3)</sup>

Series		10(11) <sup>4)</sup>
07		●
		30

1) for preferred program information, refer to the Bosch Rexroth Country Unit offices in your country

2) for metric version all sizes, see RE 92050

3) when operating on HF-fire resistant fluids, observe the limitations as shown in the relevant data sheets of the control devices and the mounted valves

4) Versions with HD-controls only in series 11

● = available ○ = in preparation - = not available

# Type code for standard program<sup>1)</sup>

	<b>(A)A4VS</b>		<b>O</b>			/			-						
01	02	03	04	05	06		07	08		09	10	11	12	13	14

### Direction of rotation

08	with view on shaft end	clockwise	<b>R</b>
		counter-clockwise	<b>L</b>

### Seals

		40	71	125	180	250	355	500	750	1000	
09	NBR (Nitrile-rubber), Shaft seal FKM (Fluoro-rubber)	●	●	●	●	●	●	●	●	●	<b>P</b>
	FKM (Fluoro-rubber) / for operation on HFD	●	●	●	●	●	●	●	●	●	<b>V</b>
	HFC-special performance version see RA 92053	-	-	●	●	●	●	-	-	-	<b>F</b>

### Shaft end

		40	71	125	180	250	355	500	750	1000	
10	SAE parallel keyed shaft to ISO 3019-1	●	●	●	●	●	●	-	-	-	<b>K</b>
	SAE splined shaft to ISO 3019-1	●	●	●	●	●	-	-	-	-	<b>S</b>
	SAE splined shaft similar to ISO 3019-1	-	-	-	-	-	●	-	-	-	<b>R</b>
	Metric keyed parallel shaft to DIN 6885	-	-	-	-	-	-	●	●	●	<b>P</b>
	Metric splined shaft to DIN 5480	-	-	-	-	-	-	●	●	●	<b>Z</b>

### Mounting flange

		40	71	125	180	250	355	500	750	1000	
11	to ISO 3019-1 (SAE J 744)      4-bolt	●	●	●	●	●	●	-	-	-	<b>D</b>
	similar to ISO 3019-2 metric      8-bolt	-	-	-	-	-	-	●	●	●	<b>H</b>

### Service line connections

12	Port B and S: SAE flange on side, 90° offset, UNC mounting bolts	●	●	●	●	●	●	-	-	-	<b>63<sup>2)</sup></b>
	Port B and S: SAE flange on side, 90° offset, 2 <sup>nd</sup> pressure port B <sub>1</sub> , opposite to B – closed with blanking plate on delivery	●	●	●	●	●	●	-	-	-	<b>75</b>
	metric mounting bolts	-	-	-	-	-	-	●	●	●	<b>25</b>

<sup>1)</sup> for preferred program information, refer to the Bosch Rexroth Country Unit offices in your country

<sup>2)</sup> only with through drive code N00 and K..

● = available    - = not available

continuation of type code see page 4

Type code for Standard program<sup>1)</sup>

	(A)A4VS		O			/			-						
01	02	03	04	05	06		07	08		09	10	11	12	13	14

Through drive			40	71	125	180	250	355	500	750	1000		
	without auxiliary pump, without through drive		●	●	●	●	●	●	●	●	●	N00	
	with through drive for mounting an axial piston unit, gear or radial piston pump		●	●	-	-	-	-	●	●	●	K...	
	Universal through drive, can be adapted		-	-	●	●	●	●	-	-	-	U...	
	Flange	splined shaft coupler <sup>2)</sup>	to mount										
	127-4 (SAE C, 4-bolt)	32-4 (SAE C)	AA4VSO/G 40	●	●	●	●	●	●	-	-	15	
	127-4 (SAE C, 4-bolt)	38-4 (SAE C-C)	AA4VSO/G 71	-	●	●	●	●	●	-	-	16	
	152-4 (SAE D, 4-bolt)	44-4 (SAE D)	AA4VSO/G 125	-	-	●	●	●	●	-	-	17	
	152-4 (SAE D, 4-bolt)	50-4 (SAE F)	AA4VSO/G 180	-	-	-	●	●	●	-	-	78	
	165-4 (SAE E, 4-bolt)	50-4 (SAE F)	AA4VSO/G 250	-	-	-	-	●	●	-	-	18	
	165-4 (SAE E, 4-bolt)	50-4 (similar to SAE F)	AA4VSO/G 355	-	-	-	-	-	●	-	-	18	
	125, 4-bolt (ISO <sup>3)</sup> )	32x2x14x9g	A4VSO/G 40	-	-	-	-	-	-	●	○	31	
	140, 4-bolt (ISO <sup>3)</sup> )	40x2x18x9g	A4VSO/G 71	-	-	-	-	-	-	●	●	33	
	160, 4-bolt (ISO <sup>3)</sup> )	50x2x24x9g	A4VSO/G 125 u. 180	-	-	-	-	-	-	●	●	34	
	224, 4-bolt (ISO <sup>3)</sup> )	60x2x28x9g	A4VSO/G, A4CSG 250	-	-	-	-	-	-	●	●	35	
	224, 4-bolt (ISO <sup>3)</sup> )	70x3x22x9g	A4VSO/G, A4CSG 355	-	-	-	-	-	-	●	○	77	
	315, 8-bolt (ISO <sup>3)</sup> )	80x3x25x9g	A4VSO/G, A4CSG 500	-	-	-	-	-	-	●	●	43	
	400, 8-bolt (ISO <sup>3)</sup> )	90x3x28x9g	A4VSO/G, A4CSG 750	-	-	-	-	-	-	-	●	○	76
13	400, 8-bolt (ISO <sup>3)</sup> )	100x3x32x9g	A4VSO/G 1000	-	-	-	-	-	-	-	-	●	88
	82-2(SAE A)	5/8in 16-4 (SAE A)	AZ-PF-1X-004...022	●	●	●	●	●	●	●	●	○	01
	82-2(SAE A)	3/4in 19-4 (SAE A-B)	A10VSO 10, 18/31/52(3)	●	●	●	●	●	●	○	○	○	52
	101-2 (SAE B)	7/8in 22-4 (SAE B)	AZ-PN-1X-020...032, (A)A10V(S)O 28/31/52(3)	●	●	●	●	●	●	●	○	○	68
	101-2 (SAE B)	1in 25-4 (SAE B-B)	PGH4, (A)A10V(S)O45/31	●	●	●	●	●	●	●	○	○	04
	127-2 (SAE C)	1 1/4in 32-4 (SAE C)	(A)A10V(S)O 71/31	-	●	●	●	●	●	●	○	○	07
	127-2 (SAE C)	1 1/2in 38-4 (SAE C-C)	PGH5, (A)A10V(S)O100/31	-	-	●	●	●	●	●	○	○	24
	152-4 (SAE D)	1 3/4in 44-4 (SAE D)	(A)A10V(S)O 140/31(2)	-	-	-	●	●	●	●	○	○	17
	80, 2-bolt (ISO <sup>3)</sup> )	3/4in 19-4 (SAE A-B)	A10VSO 10/52, 18/31	-	-	-	-	-	-	○	○	○	B2
	100, 2-bolt (ISO <sup>3)</sup> )	7/8in 22-4 (SAE B)	A10VSO 28/31	-	-	-	-	-	-	○	○	○	B3
	100, 2-bolt (ISO <sup>3)</sup> )	1in 25-4 (SAE B-B)	A10VSO 45/31	-	-	-	-	-	-	●	○	○	B4
	125, 2-bolt (ISO <sup>3)</sup> )	1 1/4in 32-4 (SAE C)	A10VSO 71/31	-	-	-	-	-	-	○	○	○	B5
	160, 4-bolt (ISO <sup>3)</sup> )	1 1/4in 32-4 (SAE C)	A10VSO 71/32	-	-	-	-	-	-	○	○	○	B8
	125, 2-bolt (ISO <sup>3)</sup> )	1 1/2in 38-4(SAE C-C)	A10VSO 100/31	-	-	-	-	-	-	○	○	○	B6
	180, 4-bolt (ISO <sup>3)</sup> )	1 1/2in 38-4 (SAE C-C)	A10VSO 100/32	-	-	-	-	-	-	○	○	○	B9
	180, 4-bolt (ISO <sup>3)</sup> )	1 3/4in 44-4 (SAE D)	A10VSO 140/31/32	-	-	-	-	-	-	●	○	○	B7
	Ø 63, metr.4-bolt for keyed shaft Ø 25	R4		●	●	○	○	○	○	○	○	○	57
	with through drive shaft, without coupler, without adapter flange, closed with cover plate			●	●	●	●	●	●	●	●	●	99

## Filtration (only with HS- and DS-control)

14	without filter	N
	Sandwich plate filter (with HS- and DS-control see RA 92076 and RE 92056)	Z

<sup>1)</sup> for preferred program information, refer to the Bosch Rexroth Country Unit offices in your country

<sup>2)</sup> Keyed shaft coupler on K/U 57 through drive      <sup>3)</sup> to ISO 3019-2 metric

## Combination pumps

- Combination pumps consisting of axial piston units – ordering example see page 38; overview mounting options see page 39
- if delivery with mounted gear or radial piston pump is desired, please consult us.

● = available    ○ = in preparation    - = not available

# Technical data

## Hydraulic fluid

For extensive information on the selection of hydraulic fluids and application conditions please consult our data sheets RA 90220 (mineral oils), RA 90221 (ecologically acceptable fluids) and RA 90223 (HF-fire resistant fluids).

The variable pump (A)A4VSO is suitable for operation on HF-fluids. (HFA, HFB, and HFC: **EA4VSO** or **A4VSO...F**  
HFD: standard version A4VSO with FKM seals)  
However, limitations to the technical data, according to RA 90223 must be observed.

**On certain selected HFC-fluids**, pump sizes **125...355**, executed in accordance to RA 92053 can be operated with the **same pressures and speeds** as on mineral oil.

On operation with HFA and HFB-fluids, limitations of the technical data must be observed according to RA 90223.

On operation with rolling oil (e.g. kerosene + additives) please consult us.

When ordering, please state the fluid to be used.

### Operating viscosity range

Within the operating viscosity range between 80...450 SUS (16...100 mm<sup>2</sup>/s) the units can be operated without limitations of the technical data.

In order to obtain optimum efficiency and service life, we recommend that the operating viscosity (at operating temperature) be selected in the range

$$v_{\text{opt}} = \text{opt. viscosity range } 80 \dots 170 \text{ SUS } (16 \dots 36 \text{ mm}^2/\text{s})$$

referred to tank temperature (open circuit).

### Limit of viscosity range

For critical operating conditions the following values apply:

$$v_{\text{min}} = 60 \text{ SUS } (10 \text{ mm}^2/\text{s})$$

for short periods ( $t < 3 \text{ min}$ )  
at max. permissible case drain temperature  
 $t_{\text{max}} = 194^\circ\text{F } (+90^\circ\text{C})$ .

$$v_{\text{max}} = 4550 \text{ SUS } (1000 \text{ mm}^2/\text{s})$$

for short periods (on cold start, operating viscosity should be below 450 SUS (100 mm<sup>2</sup>/sec) within 15 minutes)  
 $t_{\text{min}} = -13^\circ\text{F } (-25^\circ\text{C})$

For detailed information on operation with low temperatures see RA 90300-03-B.

## Selection diagram

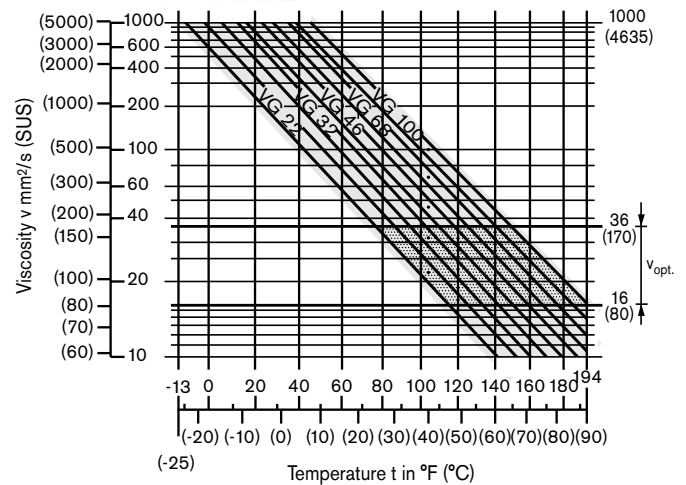

### Notes on the selection of hydraulic fluid

In order to select the correct fluid, it is necessary to know the operating temperature in the tank (open circuit) in relation to the ambient temperature.

The hydraulic fluid should be selected so that within the operating temperature range, the viscosity lies within the optimum range ( $v_{\text{opt}}$ ); see shaded section in the selection diagram. We recommend, that the higher viscosity grade is selected in each case.

### Temperature range (see selection diagram)

$$t_{\text{min}} = -13^\circ\text{F } (-25^\circ\text{C})$$

$$t_{\text{max}} = 194^\circ\text{F } (+90^\circ\text{C})$$

Example: at an ambient temperature of  $X^\circ\text{C}$  the operating temperature in the tank is  $140^\circ\text{F } (60^\circ\text{C})$ . In the optimum viscosity range ( $v_{\text{opt}}$ ; shaded area), this corresponds to grades VG 46 or VG 68; select: VG 68.

**Important:** The case drain temperature is influenced by pressure and speed and is always higher than the tank temperature. However the max. temperature at any point in the system may not exceed  $194^\circ\text{F } (90^\circ\text{C})$ .

# Technical data

## Bearing flushing

For the following operating conditions bearing flushing is required for a safe, continuous operation:

- Applications with special fluids (non mineral oils) due to limited lubricity and narrow operating temperature range
- Operation at critical conditions of temperature and viscosity with mineral oil

Flushing is recommended with vertical mounting (drive shaft facing upwards) in order to ensure lubrication of the front bearing and shaft seal.

Flushing is carried out via port „U“, located in the front flange area of the pump. The flushing fluid flows through the front bearing and leaves the pump together with the case drain flow.

Depending on pump size, the following flushing flows are recommended:

Size	40	71	125	180	250
<b>recommended flushing flow</b> $q_{Sp}$ gpm (L/min)	0.8 (3)	1.0 (4)	1.3 (5)	1.8 (7)	2.6 (10)

Size	355	500	750	1000
<b>recommended flushing flow</b> $q_{Sp}$ gpm (L/min)	4.0 (15)	5.3 (20)	7.9 (30)	10.6 (40)

These recommended flushing flows will cause a pressure drop of approx. 30 psi (2 bar) (series 1) and 45 psi (3 bar) (series 3) between the entrance to port „U“ and the pump case (including the pipe fittings).

### Notes regarding series 30

When using external bearing flushing the throttle screw at port U must be turned in to the end stop.

### Filtration of the fluid (Axial piston unit)

The finer the filtration, the better the achieved cleanliness of the fluid and the longer the life of the axial piston pump.

To ensure a reliable functioning of the axial piston unit, a minimum cleanliness class of

20/18/15 acc. to ISO 4406 is necessary.

## Case drain pressure

The permissible case drain pressure (housing pressure) is dependent on the drive speed (see diagram).

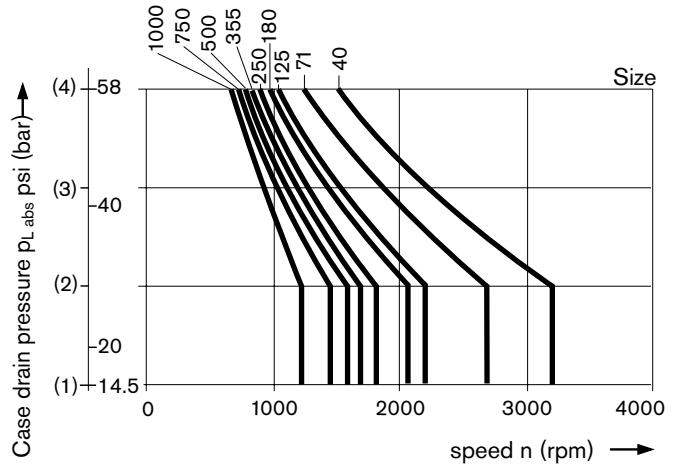

Max. case drain pressure (housing pressure)

$p_{L abs max}$  \_\_\_\_\_ 60 psi (4 bar) absolute

These are approximate values; under certain operating conditions a reduction in these values may be necessary.

# Technical data

## Operating pressure range

**Pressure at service line port (pressure port) B**

**Nominal pressure**  $p_{nom}$  \_\_\_\_\_ 5100 psi (350 bar) absolute

**Peak pressure**  $p_{max}$  \_\_\_\_\_ 5800 psi (400 bar) absolute

Total operating period \_\_\_\_\_ 300 h

Single operating period \_\_\_\_\_ 1 s

**Minimum pressure (high-pressure side)** \_\_\_\_\_ 215 psi (15 bar)  
For lower pressures please consult us.

**Rate of pressure change**  $R_A$  \_\_\_\_\_ 232000 psi/s (16000 bar/s)

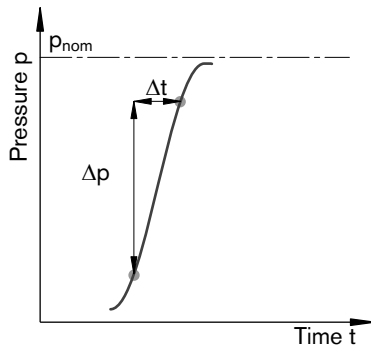

**Pressure at suction port S (inlet)**

Minimum suction pressure  $p_{S min}$  \_\_\_\_\_ 12 psi (0,8 bar) absolute

Maximum suction pressure  $p_{S max}$  \_\_\_\_\_ 435 psi (30 bar) absolute

**Minimum pressure (inlet)**

In order to avoid damage to the axial piston unit, a minimum pressure must be ensured at the suction port S (inlet). The minimum pressure is dependent on the speed and displacement of the axial piston unit.

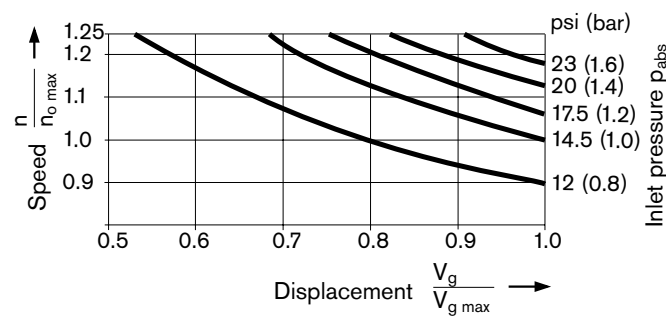

The inlet pressure is the static feed pressure or the minimum dynamic value of the boost pressure.

Please note:  
Max. permissible drive speed  $n_{o max, perm.}$  (speed limit) see page 8

Please contact us if these conditions cannot be satisfied.

## Definition

**Nominal pressure  $p_{nom}$**

The nominal pressure corresponds to the maximum design pressure.

**Peak pressure  $p_{max}$**

The peak pressure corresponds the maximum operating pressure within the single operating period. The sum of the single operating periods must not exceed the total operating period.

**Minimum pressure (high-pressure side)**

Minimum pressure on the high-pressure side (B) that is required in order to prevent damage to the axial piston unit.

**Rate of pressure change  $R_A$**

Maximum permissible rate of pressure build-up and pressure reduction during a pressure change over the entire pressure range.

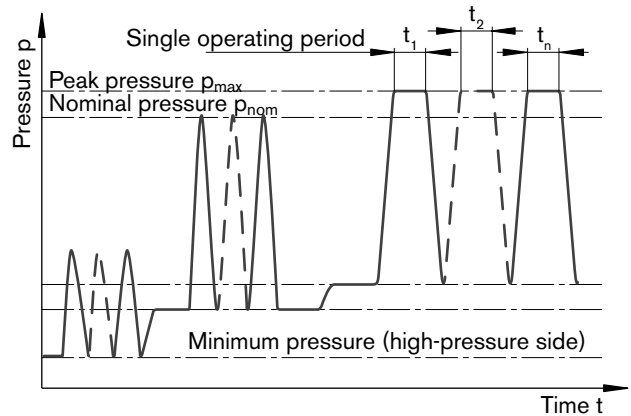

Total operating period =  $t_1 + t_2 + \dots + t_n$

# Technical data

**Table of values** (theoretical values, without considering efficiencies and tolerances; values rounded off)

Size			40	71	125	180	250/ H 1)	355/ H 1)	500/ H 1)	750	750 with boost pump	1000
Displacement	$V_{g \max}$	in <sup>3</sup> (cm <sup>3</sup> )	2.44 (40)	4.33 (71)	7.63 (125)	11.0 (180)	15.26 (250)	21.7 (355)	30.51 (500)	45.8 (750)	45.8 (750)	61.02 (1000)
Speed 2)												
max. at $V_{g \max}$	$n_{o \max}$	rpm	2600	2200	1800	1800	1500/ 1900	1500/ 1700	1320/ 1500	1200	1500	1000
max. at $V_g \leq V_{g \max}$ (speed limit)	$n_{o \max \text{ perm.}}$	rpm	3200	2700	2200	2100	1800/ 2100	1700/ 1900	1600/ 1800	1500	1500	1200
Flow												
at $n_{o \max}$	$q_{vo \max}$	gpm  (L/min)	27.5  (104)	41.2  (156)	59.4  (225)	85.6  (324)	99/ 125 475)	140/ 159 604)	174/ 198 750)	237.9  (900)	297.2  (1125)	264.1  (1000)
Power $\Delta p = 5100 \text{ psi (350 bar)}$												
at $n_{o \max}$	$P_{o \max}$	HP  (kW)	81  (61)	122  (91)	176  (131)	254  (189)	294/ 372 277)	417/ 473 352)	518/ 587 437)	708  (525)	885  (656)	781  (583)
Torque												
at $V_{g \max} \Delta p = 5100 \text{ psi (350 bar)}$	$T_{\max}$	lb-ft (Nm)	165 (223)	292 (395)	516 (696)	744 (1002)	1032 (1391)	1467 (1976)	2063 (2783)	3097 (4174)	3097 (4174)	4104 (5565)
	$T$	lb-ft (Nm)	47 (64)	83 (113)	147 (199)	211 (286)	294 (398)	417 (564)	586 (795)	880 (1193)	880 (1193)	1172 (1590)
Rotary stiffness												
Shaft end K	c	klb-ft/rad (kNm/rad)	57 (79)	106 (146)	175 (241)	235 (323)	322 (443)	592 (814)	-	-	-	-
Shaft end S	c	klb-ft/rad (kNm/rad)	49 (67)	92 (126)	141 (194)	202 (278)	267 (368)	-	-	-	-	-
Shaft end R	c	klb-ft/rad (kNm/rad)	-	-	-	-	-	345 (475)	-	-	-	-
Shaft end P	c	klb-ft/rad (kNm/rad)	-	-	-	-	-	-	832 (1145)	1352 (1860)	1352 (1860)	1985 (2730)
Shaft end Z	c	klb-ft/rad (kNm/rad)	-	-	-	-	-	-	826 (1136)	1317 (1812)	1317 (1812)	2068 (2845)
Moment of inertia rotary group	$J_{TW}$	lb-ft <sup>2</sup> (kgm <sup>2</sup> )	0.116 (0.0049)	0.287 (0.0121)	0.712 (0.03)	1.305 (0.055)	2.276 (0.0959)	4.509 (0.19)	7.809 (0.3325)	15.66 (0.66)	15.66 (0.66)	28.47 (1.20)
Angular acceleration max. 4)	$\alpha$	rad/s <sup>2</sup>	17000	11000	8000	6800	4800	3600	2800	2000	2000	1450
Case volume	$V$	gal (L)	0.5(2)	0.6(2.5)	1.3(5)	1.0(4)	2.6(10)	2.1(8)	3.7(14)	5.0(19)	5.8(22)	7.13(27)
Weight (with pressure control) approx.	$m$	lbs (kg)	86 (39)	117 (53)	194 (88)	225 (102)	406 (184)	456 (207)	705 (320)	1014 (460)	1080 (490)	1333 (605)

1) High-Speed-Version

2) Values are valid with inlet pressure  $p_{\text{abs}}$  14.5 psi (1 bar) at inlet port S, with increased speed up to speed limit please observe diagram, page 7

3)  $V_g < V_{g \max}$

4) – The range of validity lies between zero and the maximum permissible drive speeds.

Valid for external excitation (eg. diesel engine 2- to 8-fold rotary frequency, cardan shaft 2-fold rotary frequency).

– The limiting value is only valid for a single pump.

– The loading capacity of the connecting parts must be considered.

## Notes

Exceeding the maximum or falling below the minimum permissible values can lead to a loss of function, a reduction in operational service life or total destruction of the axial piston unit.

The permissible values can be determined through calculation.



# Technical data

## Permissible radial and axial forces on the drive shaft

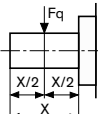
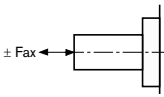
Size		40	71	125	180	250	355	500	750*	1000	
Radial force, max.	 at X/2 $F_{q\ max}$	lb (N)	225 (1000)	270 (1200)	360 (1600)	450 (2000)	450 (2000)	495 (2200)	560 (2500)	675 (3000)	786 (3500)
Axial force, max.	 $\pm F_{ax\ max}$	lb (N)	135 (600)	180 (800)	225 (1000)	315 (1400)	405 (1800)	450 (2000)	450 (2000)	495 (2200)	495 (2200)

\* also valid for versions with boost pump

## Determination of pump size

Flow  $q_v = \frac{V_g \cdot n \cdot \eta_v}{231} \text{ [gpm]} \left( \frac{V_g \cdot n \cdot \eta_v}{1000} \text{ [L/min]} \right)$

Drive torque  $T = \frac{V_g \cdot \Delta p}{24 \cdot \pi \cdot \eta_{mh}} \text{ [lb-ft]} \left( \frac{V_g \cdot \Delta p}{20 \cdot \pi \cdot \eta_{mh}} \text{ [Nm]} \right)$

Power  $P = \frac{q_v \cdot \Delta p}{1714 \cdot \eta_t} \text{ [HP]} \left( \frac{q_v \cdot \Delta p}{600 \cdot \eta_t} \text{ [kW]} \right)$

$V_g$  = geometr. displacement per rev. in  $\text{in}^3$  ( $\text{cm}^3$ )

$\Delta p$  = pressure difference in psi (bar)

$n$  = speed in rpm

$\eta_v$  = volumetric efficiency

$\eta_{mh}$  = mechanical-hydraulic efficiency

$\eta_t$  = overall efficiency ( $\eta_t = \eta_v \cdot \eta_{mh}$ )

# Characteristics

## Drive power and flow

(Fluid: Hydraulic oil ISO VG 46 DIN 51519, t = 122°F (50°C))

Overall efficiency:  $\eta_t = \frac{q_v \cdot p}{P_{q_v \max} \cdot 1714}$   $\left( \eta_t = \frac{q_v \cdot p}{P_{q_v \max} \cdot 600} \right)$  Volumetric efficiency:  $\eta_v = \frac{q_v}{q_{v \text{ theor}}}$

$q_v = \text{gpm}$      $q_v = \text{L/min}$   
 $p = \text{psi}$      $p = \text{bar}$   
 $P = \text{HP}$      $P = \text{kW}$

**Size 40**

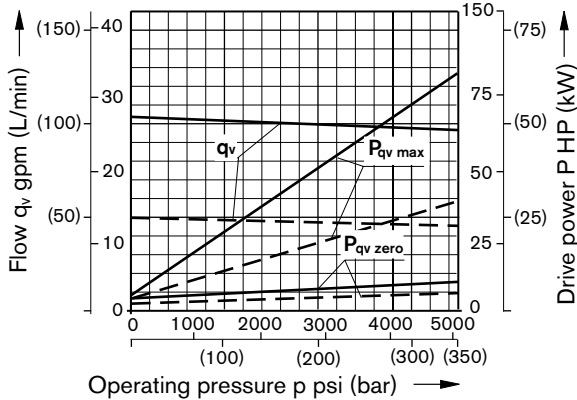

—  $n = 2600 \text{ rpm}$   
 - - -  $n = 1200 \text{ rpm}$

**Size 180**

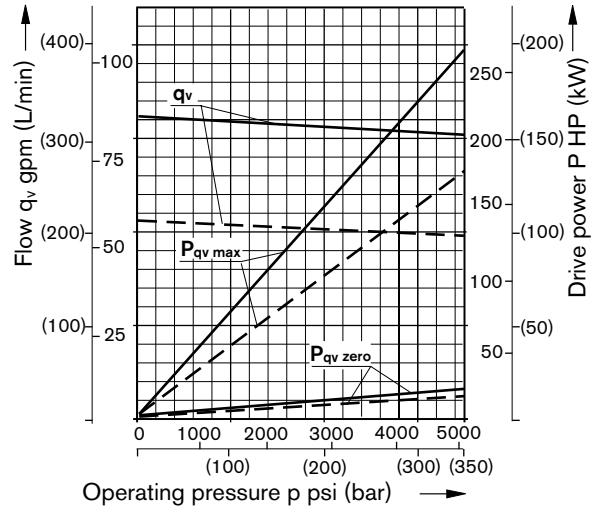

—  $n = 1800 \text{ rpm}$   
 - - -  $n = 1200 \text{ rpm}$

**Size 71**

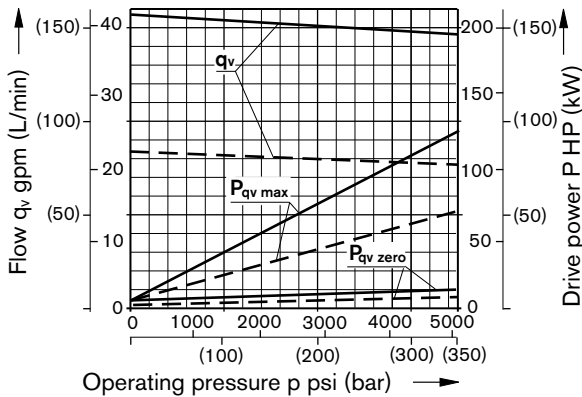

—  $n = 2200 \text{ rpm}$   
 - - -  $n = 1200 \text{ rpm}$

**Size 250**

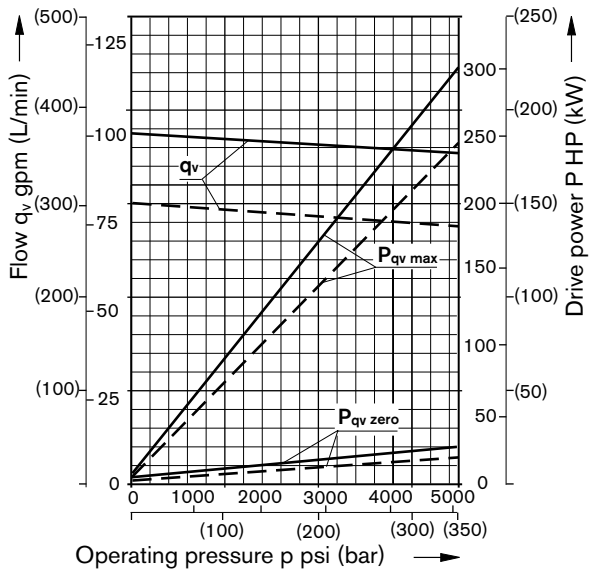

—  $n = 1500 \text{ rpm}$   
 - - -  $n = 1200 \text{ rpm}$

**Size 125**

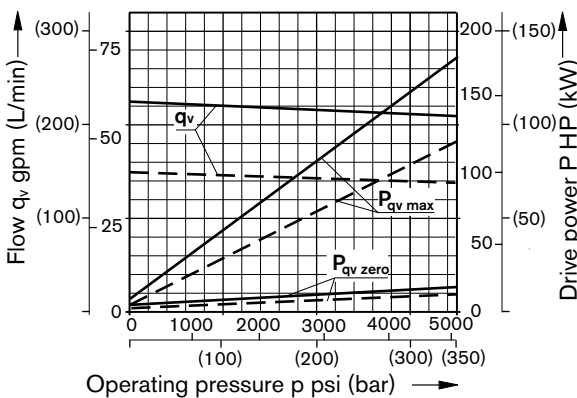

—  $n = 1800 \text{ rpm}$   
 - - -  $n = 1200 \text{ rpm}$

# Characteristics

## Drive power and flow

(Fluid: Hydraulic oil ISO VG 46 DIN 51519, t = 122°F (50°C))

Overall efficiency:  $\eta_t = \frac{q_v \cdot p}{P_{qv \max} \cdot 1714}$   $\left( \eta_t = \frac{q_v \cdot p}{P_{qv \max} \cdot 600} \right)$  Volumetric efficiency:  $\eta_v = \frac{q_v}{q_{v \text{ theor}}}$

$q_v = \text{gpm}$       $q_v = \text{L/min}$   
 $p = \text{psi}$       $p = \text{bar}$   
 $P = \text{HP}$       $P = \text{kW}$

**Size 355**

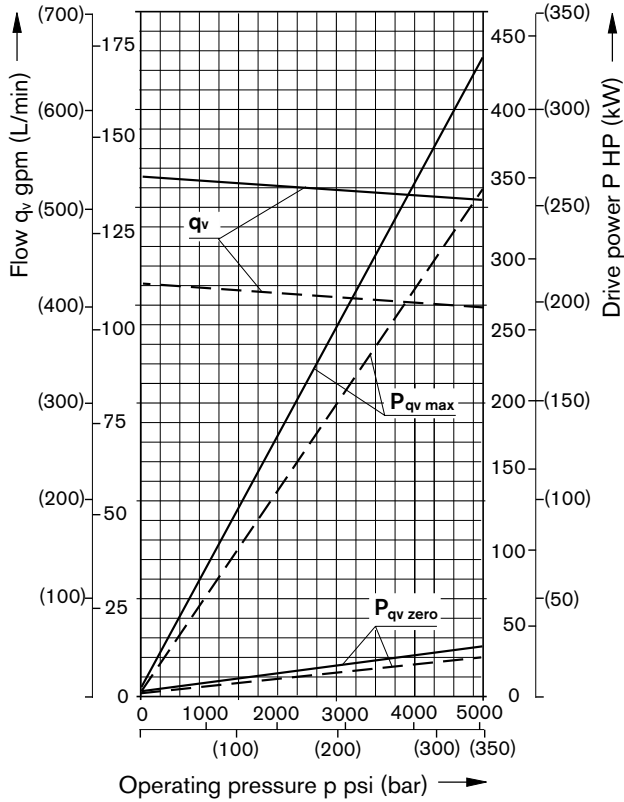

— n = 1500 rpm  
 - - - n = 1200 rpm

**Size 500**

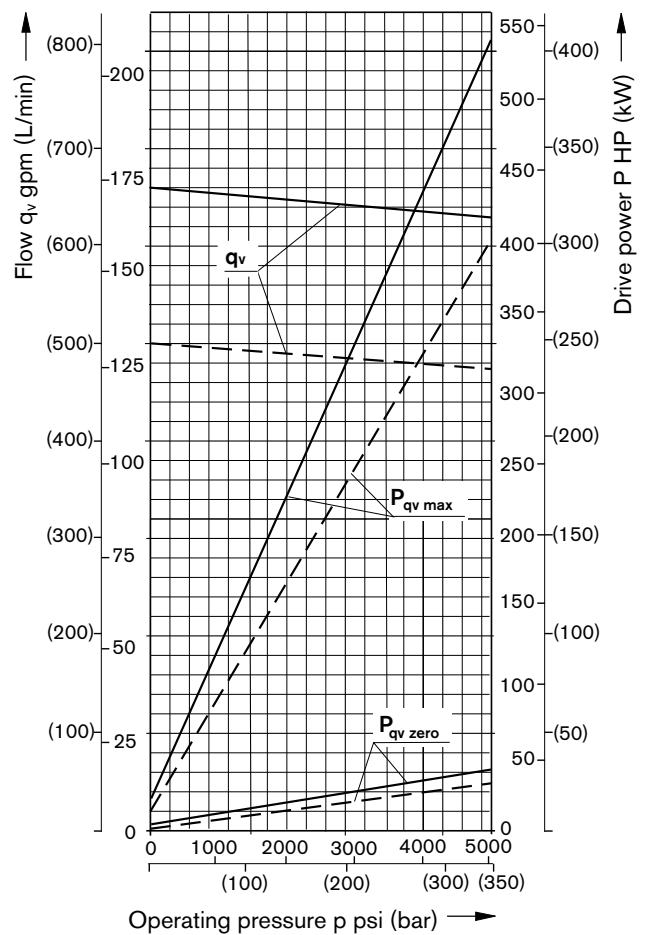

— n = 1320 rpm  
 - - - n = 1000 rpm

# Characteristics

## Drive power and flow

(Fluid: Hydraulic oil ISO VG 46 DIN 51519, t = 122°F (50°C))

Overall efficiency:  $\eta_t = \frac{q_v \cdot p}{P_{q_v \max} \cdot 1714}$   $\left( \eta_t = \frac{q_v \cdot p}{P_{q_v \max} \cdot 600} \right)$  Volumetric efficiency:  $\eta_v = \frac{q_v}{q_{v \text{ theor}}}$

$q_v = \text{gpm}$       $q_v = \text{L/min}$   
 $p = \text{psi}$       $p = \text{bar}$   
 $P = \text{HP}$       $P = \text{kW}$

Size 750

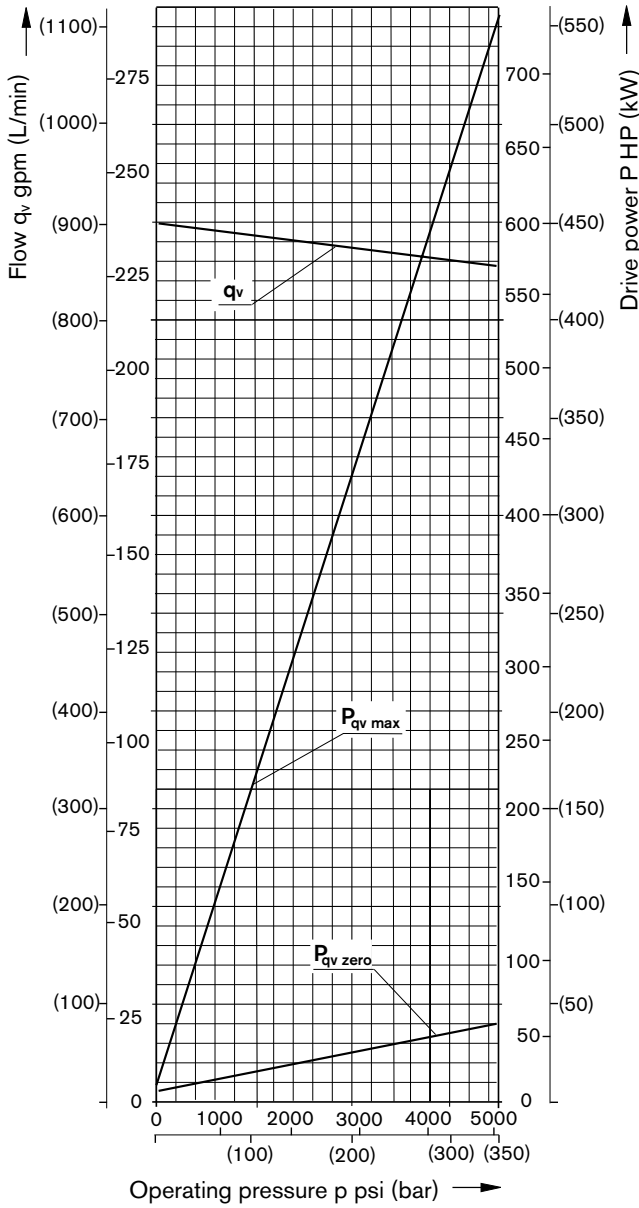

—  $n = 1200$  rpm

Size 1000

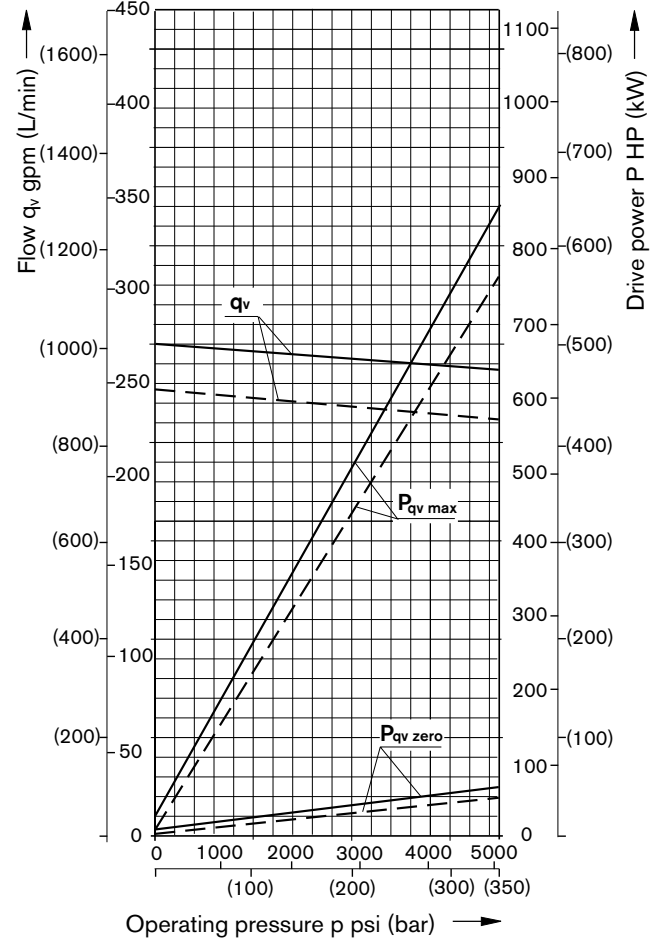

—  $n = 1000$  rpm  
 - - -  $n = 900$  rpm

# Summary of controls

## Pressure control DR (see RA 92060)

The DR- pressure control limits the maximum pressure at the pump outlet within the pump's control range. This max. pressure level can be steplessly set at the control valve.

Setting range 725...5100 psi (50...350 bar)

Optional:  
Remote control (DRG)

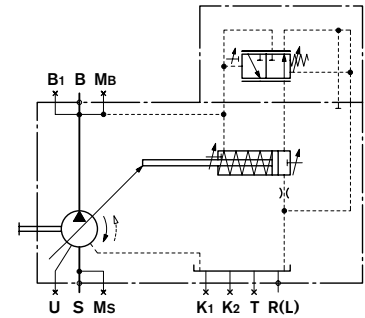
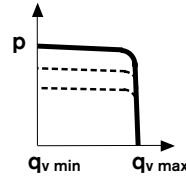

## Pressure control for parallel operation DP (see RA 92060)

Suitable for pressure control with multiple A4VSO axial piston pumps in parallel operation.

Optional:  
Flow control (DPF)

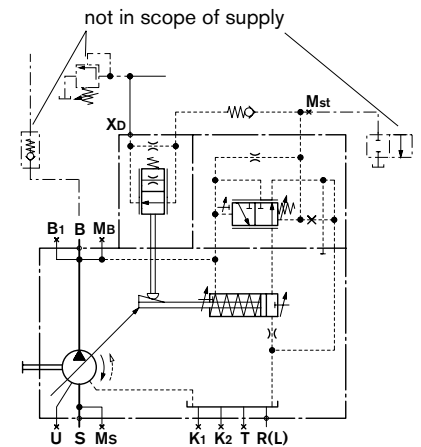
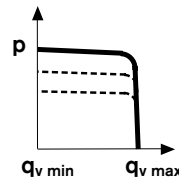

## Flow control FR (see RA 92060)

Maintains a constant flow in a hydraulic system.

Optional:  
Remote pressure control (FRG)  
connection between  $X_F$  and tank closed (FR1, FRG1)

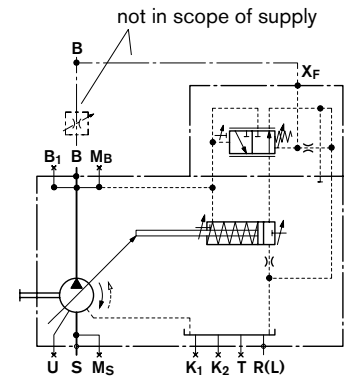
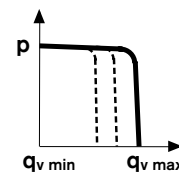

## Pressure and flow control DFR (see RA 92060)

This control maintains a constant flow from the pump even under varying operating conditions. Overriding this control is a mechanically adjustable pressure control.

Optional:  
connection between  $X_F$  and tank closed (DFR1)

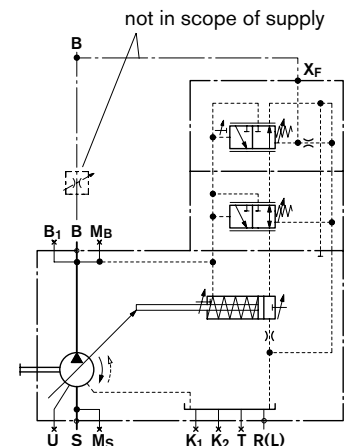
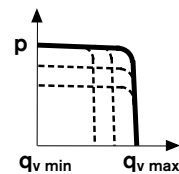

# Summary of controls

## Power control LR2 with hyperbolic characteristic (see RA 92064)

The hyperbolic power control maintains a constant preset drive power at the same input speed.

Optional:

- Pressure control (LR2D), remotely controlled (LR2G);
- Flow control (LR2F, LR2S);
- Hydraulic stroke limiter (LR2H);
- Mechanical stroke limiter (LR2M);
- Hydraulic two-point control (LR2Z);
- with electric unloading valve for easy start (LR2Y).

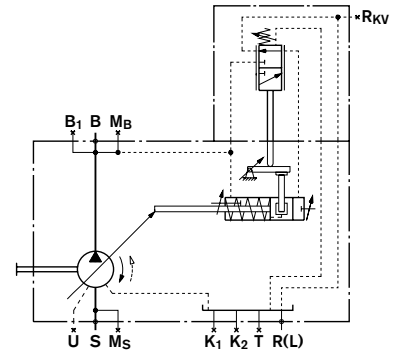
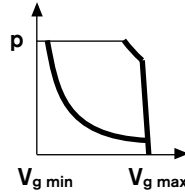

## Power control LR3 with remote control of power characteristics (see RA 92064)

This power control maintains a constant preset drive power, with remote control of the power characteristics.

Optional:

- Pressure control (LR3D), remotely controlled (LR3G);
- Flow control (LR3F, LR3S);
- Hydraulic stroke control (LR3H);
- Mechanical stroke control (LR3M);
- Hydraulic two-point control (LR3Z);
- with electric unloading valve for easy start (LR3Y)

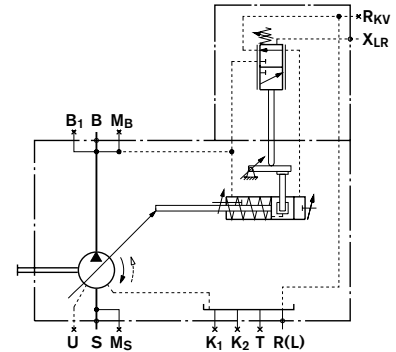
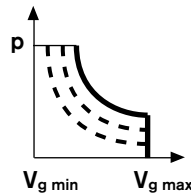

## Hydraulic control LR2N and LR3N pilot pressure dependent, initial position $V_{g \min}$ (see RA 92064)

With overriding power control.

The pump displacement is proportional to a pilot pressure signal in  $P_{St}$ .  
The additional hyperbolic power control overrides the pilot pressure signal and holds the preset drive power constant.

Optional:

- Remote control of power characteristics (LR3N)
- Pressure control (LR.DN),
- Remote pressure control (LR.GN)
- Electric control of pilot pressure signal (LR.NT)

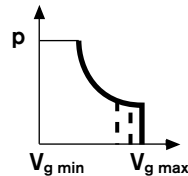
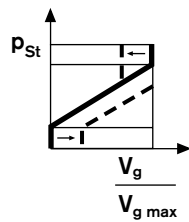

shown in shifted position

i.e. P pressurized

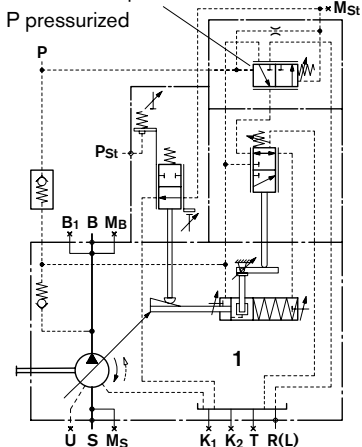

# Summary of controls

## Manual control MA (see RE 92072)

Stepless adjustment of displacement by means of a handwheel.

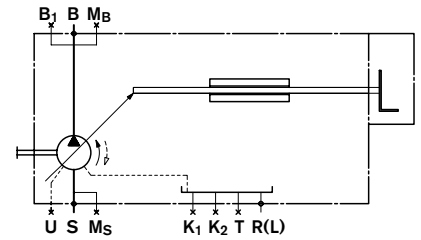
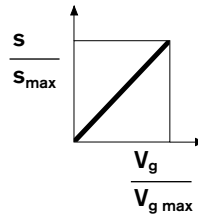

## Electric motor control EM (see RE 92072)

Stepless adjustment of displacement via an electric motor.

Various intermediate displacement values can be selected with a programmed sequence control, by means of built on limit switches and an optional potentiometer for feedback signal.

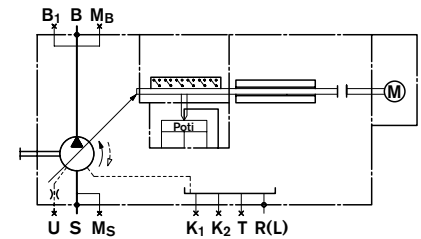
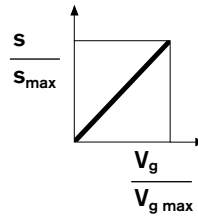

## Hydraulic control HD pilot pressure dependent (see RA 92080)

Stepless adjustment of displacement proportional to a pilot pressure signal. The displacement is proportional to the applied pilot pressure (Difference between pilot pressure level and pump case pressure).

Optional:

Pilot pressure curves (HD1, HD2, HD3)

Pressure control (HD.B),

Remote pressure control (HD.GB)

Power control (HD1P)

with electric control of pilot pressure (HD1T)

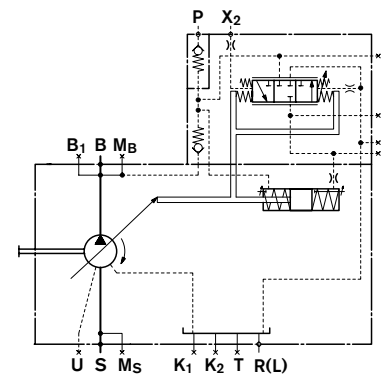
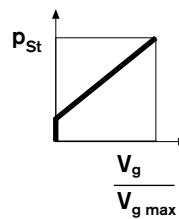

# Summary of controls

## Hydraulic control HM 1/2, control volume dependent (see RA 92076)

The pump displacement is infinitely variable in relation to the control oil volume in ports  $X_1$  and  $X_2$ .

Application:

- 2-point control
- basic control device for servo or proportional valve control

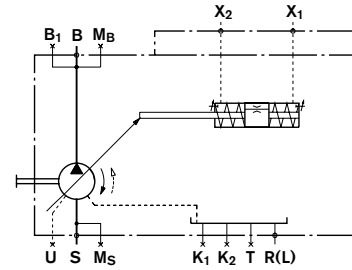

## Control system HS, HS4, with servo or proportional valve (see RA 92076)

The stepless displacement control is accomplished by means of servo or proportional valve with electrical feedback of the swivel angle. The HS4P-control system is fitted with a built on pressure transducer so that it can be utilized for electrical pressure and power control.

Optional:

- Servo valve (HS);
- Proportional valve (HS4);
- Short circuit valve (HSK, HS4K, HS4KP);
- Without valves (HSE, HS4E).
- For oil-immersed use (HS4M)

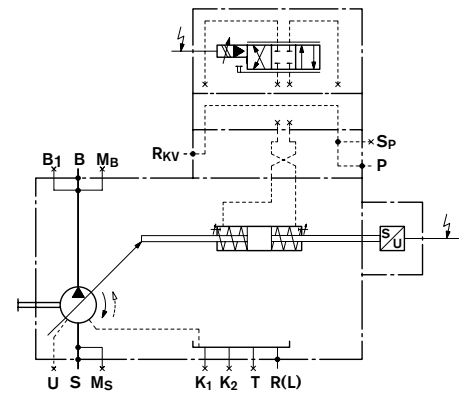
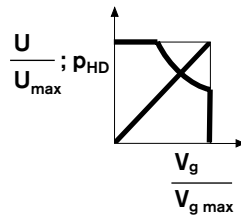

## Control system EO1/2 (see RA 92076)

The stepless adjustment of the displacement is accomplished by means of a proportional valve with electrical feedback of the swivel angle. This control can be utilized as an electric control of displacement.

Optional:

- Control pressure range (EO1, EO2)
- Short circuit valve (EO1K, EO2K)
- Without valves (EO1E, EO2E)

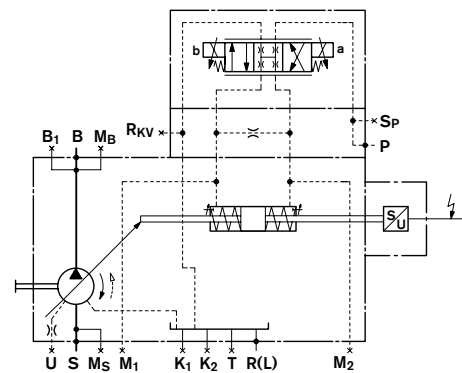
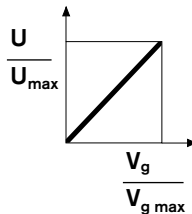



# Summary of controls

## Speed control DS1, secondary controlled (see RE 92056)

The speed control DS1 controls the secondary unit (motor) in such a manner, that this motor delivers sufficient torque to maintain the required output speed. When connected to a constant pressure system, this torque is proportional to motor displacement and thus also proportional to the swivel angle.

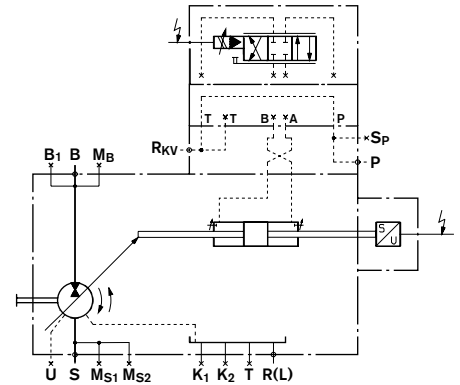
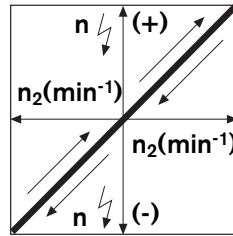

## Electro hydraulic control system DFE1 (see RE 92088)

The power, pressure and swivel angle control of the variable pump A4VSO...DFE1 is accomplished by means of an electrically controlled proportional valve. A current signal to the proportional valve moves the control piston and determines via an integrated positional transducer the cradle's swivel angle and thus the pump flow. When the electric drive motor is switched off and the system is pressureless, the bias spring in the control chamber will swivel the pump to max. displacement ( $V_{g \text{ max}}$ ).

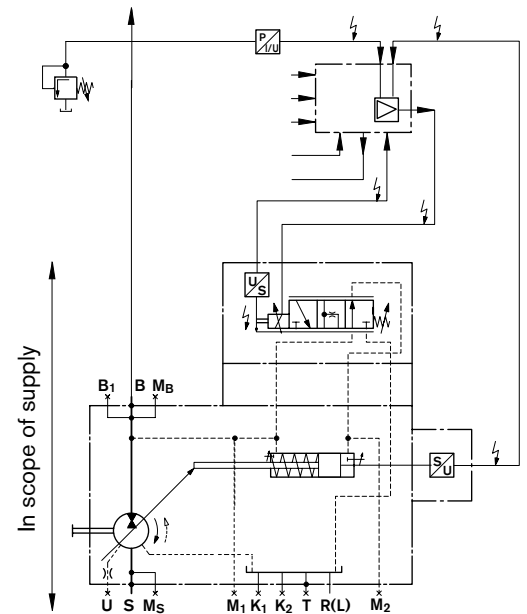
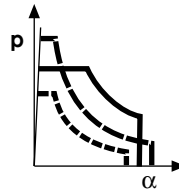

# Dimensions, size 40

Before finalising your design please request a certified installation drawing. Dimensions in inches (mm).

## Series 1

Example: SAE with N00

pressure control; for exact dimensions of the control devices see separate data sheets

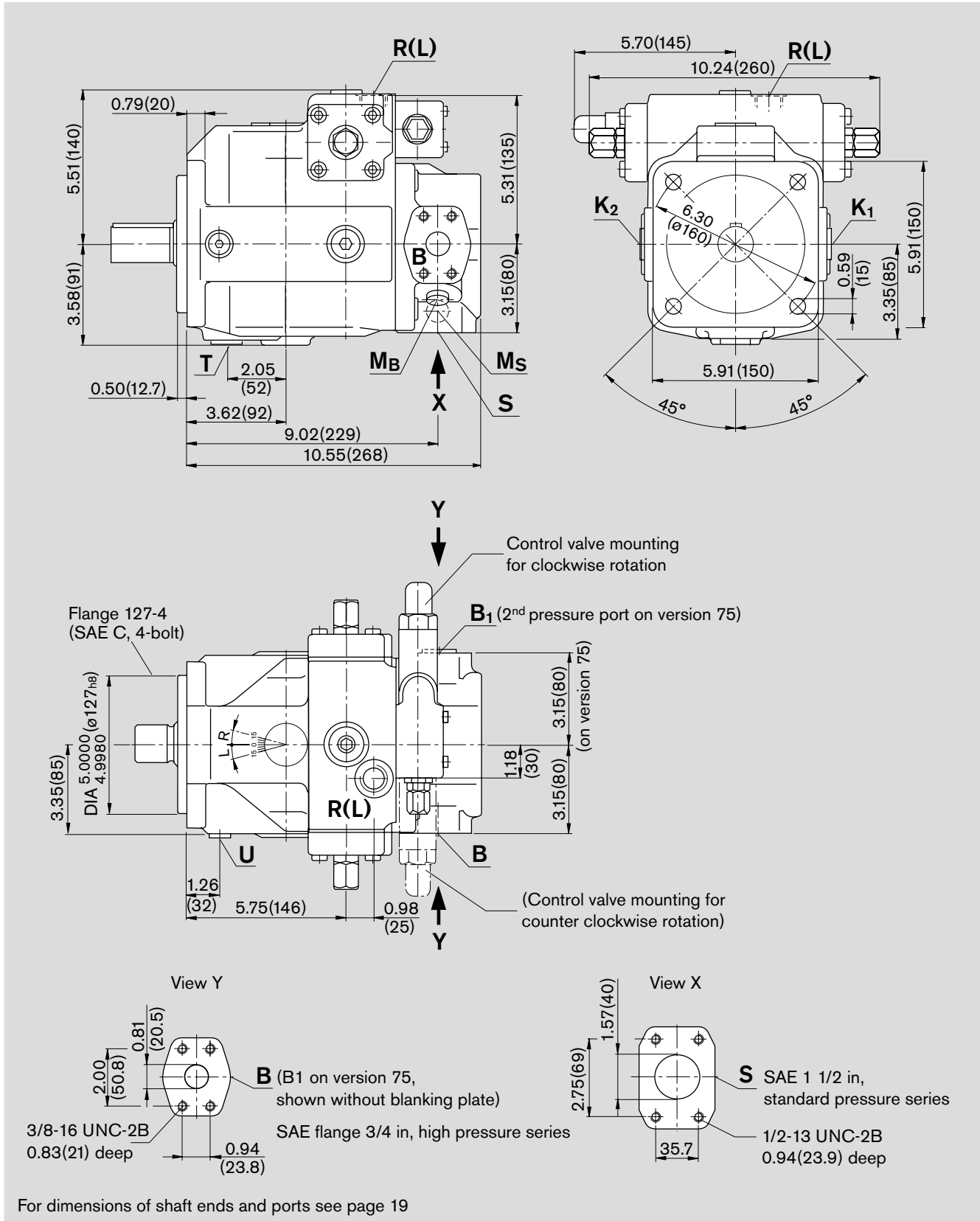

# Dimensions, size 40

Before finalising your design please request a certified installation drawing. Dimensions in inches (mm).

## Shaft ends

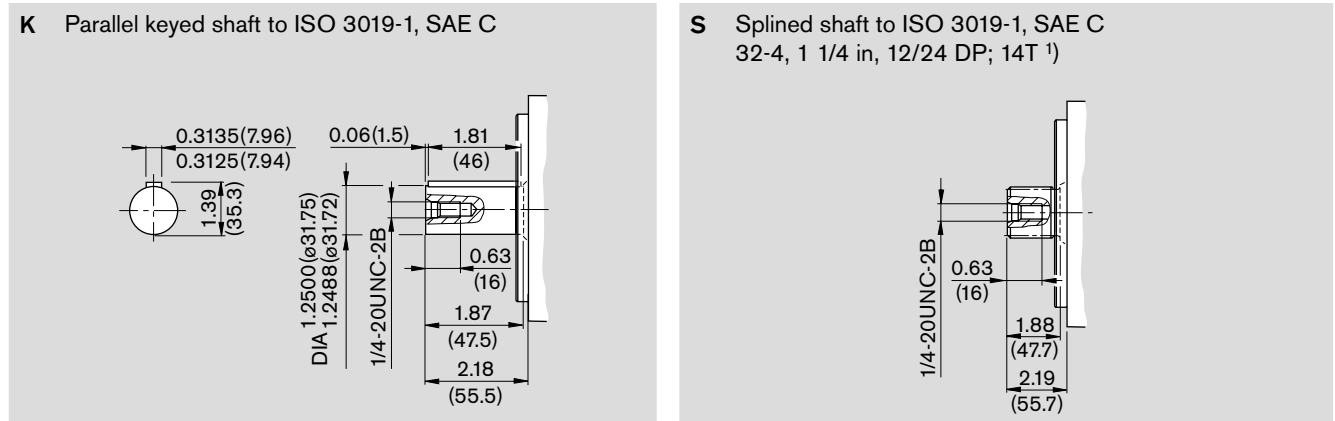

## Ports

max. tightening torque <sup>2)</sup>

S	Suction port (standard pressure series)	SAE J518	1 1/2 in	
	Mounting bolts	ISO 68	1/2-13UNC-2B; 0.94(24) deep <sup>2)</sup>	
K <sub>1</sub> , K <sub>2</sub>	Flushing port	ISO 11926	7/8-14UNF-2B; 0.67(17) deep (plugged)	175 lb-ft (240 Nm)
T	Drain	ISO 11926	7/8-14UNF-2B; 0.67(17) deep (plugged)	175 lb-ft (240 Nm)
M <sub>B</sub>	Gauge port outlet pressure	ISO 11926	7/16-20UNF-2B; 0.39(10) deep (plugged)	29 lb-ft (40 Nm)
M <sub>S</sub>	Gauge port suction pressure	ISO 11926	7/16-20UNF-2B; 0.39(10) deep (plugged)	29 lb-ft (40 Nm)
R(L)	Fill and bleed (case drain port)	ISO 11926	7/8-14UNF-2B; 0.67(17) deep	175 lb-ft (240 Nm)
U	Flushing port	ISO 11926	7/16-20UNF-2B; 0.39(10) deep (plugged)	29 lb-ft (40 Nm)
<b>on version 63</b>				
B	Pressure port (high pressure series)	SAE J518	3/4 in	
	Mounting bolts	ISO 68	3/8-16UNC-2B; 0.83(21) deep <sup>2)</sup>	
B <sub>1</sub>	Additional port	ISO 11926	7/8-14UNF-2B; 0.67(17) deep (plugged)	175 lb-ft (240 Nm)
<b>on version 75</b>				
B	Pressure port (high pressure series)	SAE J518	3/4 in	
	Mounting bolts	ISO 68	3/8-16UNC-2B; 0.83(21) deep <sup>2)</sup>	
B <sub>1</sub>	2 <sup>nd</sup> press. port (high pressure series)	SAE J518	3/4 in (closed with blanking plate)	
	Mounting bolts	ISO 68	3/8-16UNC-2B; 0.83(21) deep <sup>2)</sup>	

<sup>1)</sup> ANSI B92.1a-1976, 30° pressure angle, flat base, flank centering, fit class 5

<sup>2)</sup> for the max. tightening torques please observe the manufacturer's information on the used fittings and the general information on page 64

# Dimensions, size 71

Before finalising your design please request a certified installation drawing. Dimensions in inches (mm).

## Series 1

Example: SAE with N00

pressure control; for exact dimensions of control devices see separate data sheets

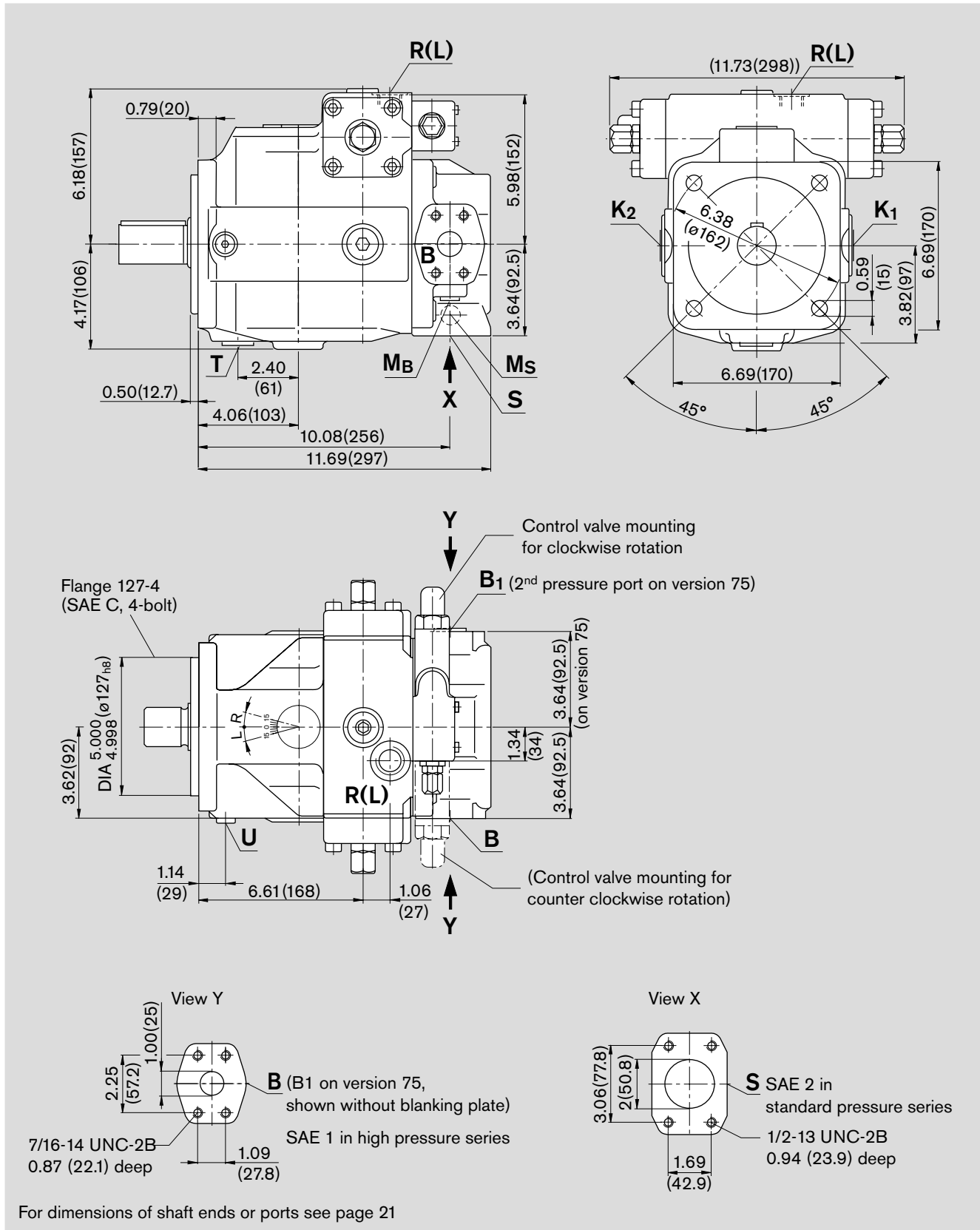

For dimensions of shaft ends or ports see page 21

# Dimensions, size 71

Before finalising your design please request a certified installation drawing. Dimensions in inches (mm).

## Shaft ends

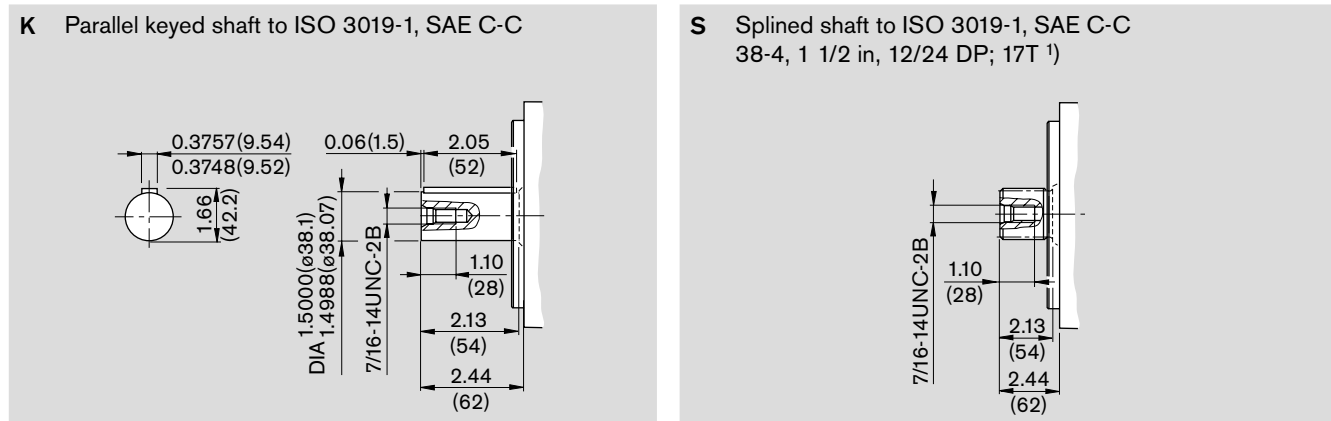

## Ports

max. tightening torque <sup>2)</sup>

S	Suction port (standard pressure series)	SAE J518	1 1/2 in	
	Mounting bolts	ISO 68	1/2-13UNC-2B; 0.87(22) deep <sup>2)</sup>	
K <sub>1</sub> , K <sub>2</sub>	Flushing port	ISO 11926	1 1/16-12UN-2B; 0.79(20) deep (plugged)	265 lb-ft (360 Nm)
T	Drain	ISO 11926	1 1/16-12UN-2B; 0.79(20) deep (plugged)	265 lb-ft (360 Nm)
M <sub>B</sub>	Gauge port outlet pressure	ISO 11926	7/16-20UNF-2B; 0.39(10) deep (plugged)	29 lb-ft (40 Nm)
M <sub>S</sub>	Gauge port suction pressure	ISO 11926	7/16-20UNF-2B; 0.39(10) deep (plugged)	29 lb-ft (40 Nm)
R(L)	Fill + air bleed (case drain port)	ISO 11926	1 1/16-12UN-2B; 0.79(20) deep	265 lb-ft (360 Nm)
U	Flushing port	ISO 11926	7/16-20UNF-2B; 0.39(10) deep (plugged)	29 lb-ft (40 Nm)

### on version 63

B	Pressure port (high pressure series)	SAE J518	1 in	
	Mounting bolts	ISO 68	7/16-14UNC-2B; 0.87(22) deep <sup>2)</sup>	
B <sub>1</sub>	Additional port	ISO 11926	1 1/16-12UN-2B; 0.79(20) deep (plugged)	265 lb-ft (360 Nm)

### on version 75

B	Pressure port (high pressure series)	SAE J518	1 in	
	Mounting bolts	ISO 68	7/16-14UNC-2B; 0.87(22) deep <sup>2)</sup>	
B <sub>1</sub>	2 <sup>nd</sup> pressure port (high pressure series)	SAE J518	1 in (closed with blanking plate)	
	Mounting bolts	ISO 68	7/16-14UNC-2B; 0.87(22) deep <sup>2)</sup>	

<sup>1)</sup> ANSI B92.1a–1976, 30° pressure angle, flat base, flank centering, fit class 5

<sup>2)</sup> for the max. tightening torques please observe the manufacturer's information on the used fittings and the general information on page 64

# Dimensions, size 125

Before finalising your design please request a certified installation drawing. Dimensions in inches (mm).

## Series 3

Example: SAE with N00 (for U99 dimensions, see page 61) pressure control; for exact dimensions of control devices see separate data sheets

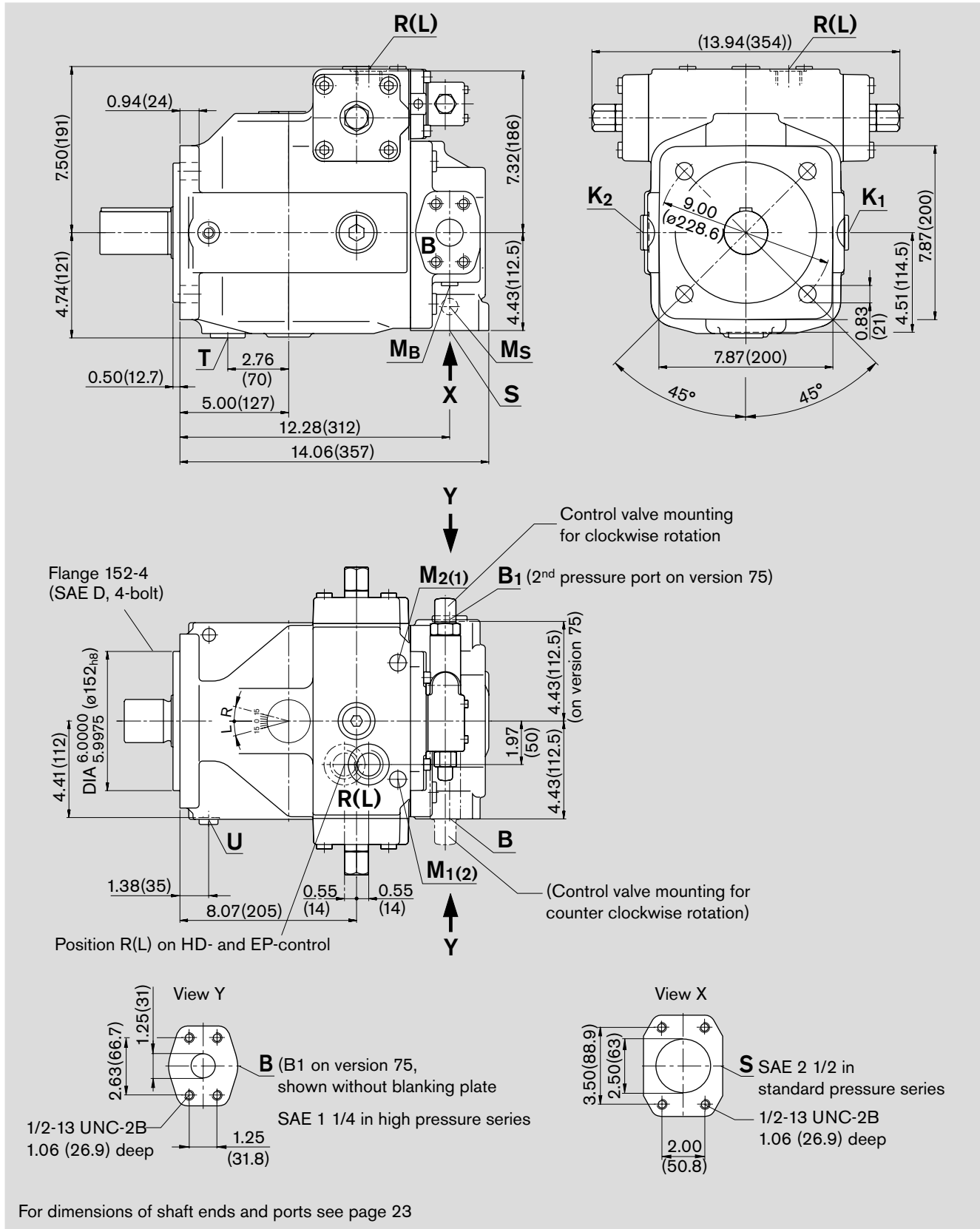

For dimensions of shaft ends and ports see page 23

# Dimensions, size 125

Before finalising your design please request a certified installation drawing. Dimensions in inches (mm).

## Shaft ends

**K** Parallel keyed shaft to ISO 3019-1, SAE D

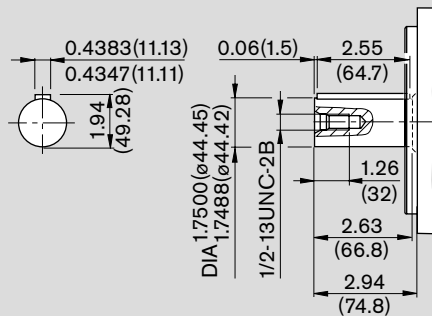

**S** Splined shaft to ISO 3019-1, SAE D  
44-4, 1 3/4 in, 8/16 DP; 13T <sup>1)</sup>

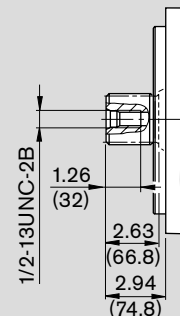

## Ports

max. tightening torque <sup>2)</sup>

S	Suction port (standard pressure series)	SAE J518	2 1/2 in	
	Mounting bolts	ISO 68	1/2-13UNC-2B; 1.06(27) deep <sup>2)</sup>	
K <sub>1</sub> , K <sub>2</sub>	Flushing port	ISO 11926	1 5/16-12UN-2B; 0.79(20) deep (plugged)	394 lb-ft (540 Nm)
T	Drain	ISO 11926	1 5/16-12UN-2B; 0.79(20) deep (plugged)	394 lb-ft (540 Nm)
M <sub>B</sub>	Gauge port outlet pressure	ISO 11926	7/16-20UNF-2B; 0.39(10) deep (plugged)	29 lb-ft (40 Nm)
M <sub>S</sub>	Gauge port suction pressure	ISO 11926	7/16-20UNF-2B; 0.39(10) deep (plugged)	29 lb-ft (40 Nm)
R(L)	Fill + air bleed (case drain port)	ISO 11926	1 5/16-12UN-2B; 0.79(20) deep	394 lb-ft (540 Nm)
U	Flushing port	ISO 11926	7/16-20UNF-2B; 0.39(10) deep (plugged)	29 lb-ft (40 Nm)
M <sub>1</sub> , M <sub>2</sub>	Gauge port control chamber press.	DIN 3852	M14x1.5; 0.47(12) deep (plugged)	29 lb-ft (40 Nm)

### on version 63

B	Pressure port (high pressure series)	SAE J518	1 1/4 in	
	Mounting bolts	ISO 68	1/2-13UNC-2B; 1.06(27) deep <sup>2)</sup>	
B <sub>1</sub>	Additional port	ISO 11926	1 5/16-12UN-2B; 0.79(20) deep (plugged)	394 lb-ft (540 Nm)

### on version 75

B	Pressure port (high pressure series)	SAE J518	1 1/4 in	
	Mounting bolts	ISO 68	1/2-13UNC-2B; 1.06(29) deep <sup>2)</sup>	
B <sub>1</sub>	2 <sup>nd</sup> pressure port (high pressure series)	SAE J518	1 1/4 in (closed with blanking plate)	
	Mounting bolts	ISO 68	1/2-13UNC-2B; 1.06(29) deep <sup>2)</sup>	

<sup>1)</sup> ANSI B92.1a–1976, 30° pressure angle, flat base, flank centering, fit class 5

<sup>2)</sup> for the max. tightening torques please observe the manufacturer's information on the used fittings and the general information on page 64

# Dimensions, size 180

Before finalising your design please request a certified installation drawing. Dimensions in inches (mm).

## Series 3

Example: SAE with N00 (for U99 dimensions see page 61)  
pressure control; for exact dimensions of control devices see separate data sheets

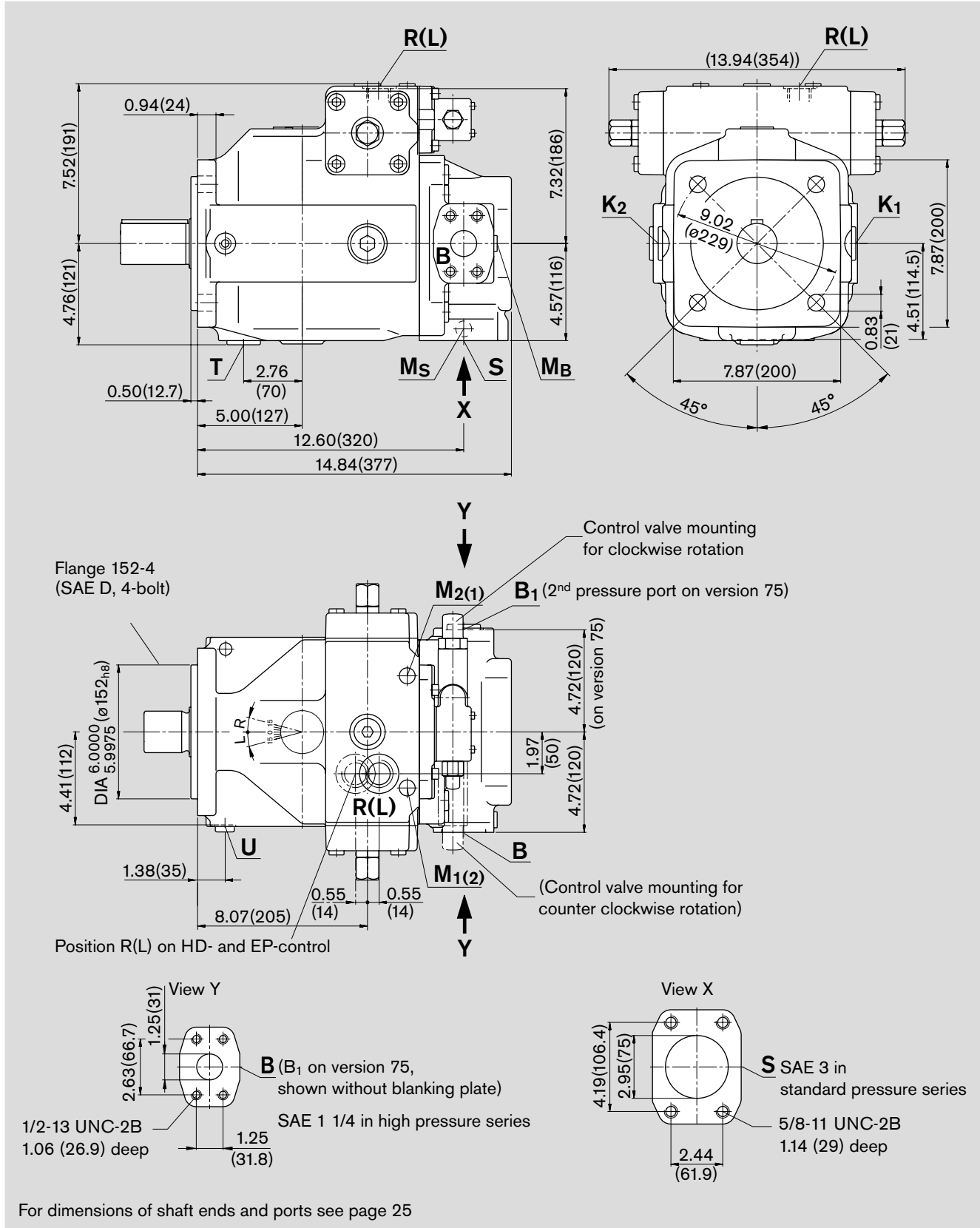



# Dimensions, size 180, SAE with N00<sup>3)</sup>

Before finalising your design please request a certified installation drawing. Dimensions in inches (mm).

## Shaft ends

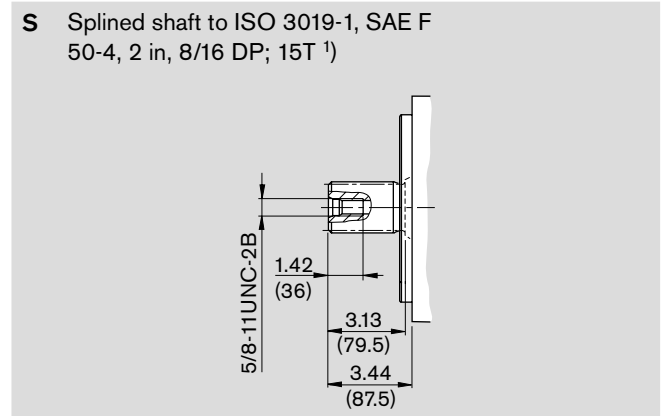
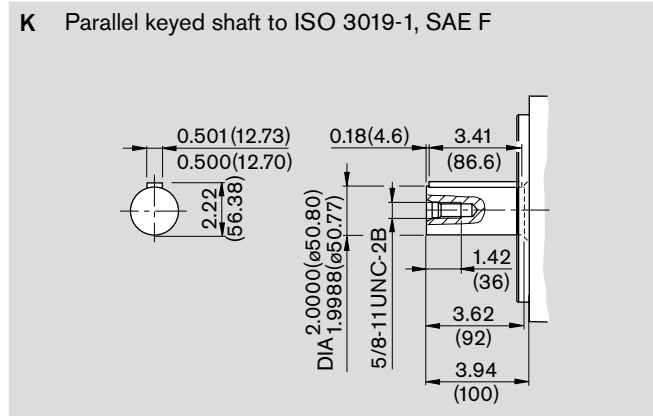

## Ports

max. tightening torque <sup>2)</sup>

S	Suction port (standard pressure series)	SAE J518	3 in	
	Mounting bolts	ISO 68	5/8-11UNC-2B; 1.14(29) deep <sup>2)</sup>	
K <sub>1</sub> , K <sub>2</sub>	Flushing port	ISO 11926	1 5/16-12UN-2B; 0.79(20) deep (plugged)	394 lb-ft (540 Nm)
T	Drain	ISO 11926	1 5/16-12UN-2B; 0.79(20) deep (plugged)	394 lb-ft (540 Nm)
M <sub>B</sub>	Gauge port outlet pressure	ISO 11926	7/16-20UNF-2B; 0.39(10) deep (plugged)	29 lb-ft (40 Nm)
M <sub>S</sub>	Gauge port suction pressure	ISO 11926	7/16-20UNF-2B; 0.39(10) deep (plugged)	29 lb-ft (40 Nm)
R(L)	Fill + air bleed (case drain port)	ISO 11926	1 5/16-12UN-2B; 0.79(20) deep	394 lb-ft (540 Nm)
U	Flushing port	ISO 11926	7/16-20UNF-2B; 0.39(10) deep (plugged)	29 lb-ft (40 Nm)
M <sub>1</sub> , M <sub>2</sub>	Gauge port control chamber pressure	DIN 3852	M14x1,5; 0.47(12) deep (plugged)	58 lb-ft (80 Nm)

### on version 63

B	Pressure port (high pressure series)	SAE J518	1 1/4 in	
	Mounting bolts	ISO 68	1/2-13UNC-2B; 1.06(27) deep <sup>2)</sup>	
B <sub>1</sub>	Additional port	ISO 11926	1 5/16-12UN-2B; 0.79(20) deep (plugged)	394 lb-ft (540 Nm)

### on version 75

B	Pressure port (high pressure series)	SAE J518	1 1/4 in	
	Mounting bolts	ISO 68	1/2-13UNC-2B; 1.06(27) deep <sup>2)</sup>	
B <sub>1</sub>	2 <sup>nd</sup> pressure port (high pressure series)	SAE J518	1 1/4 in (closed with blanking plate)	
	Mounting bolts	ISO 68	1/2-13UNC-2B; 1.06(27) deep <sup>2)</sup>	

<sup>1)</sup> ANSI B92.1a–1976, 30° pressure angle, flat base, flank centering, fit class 5

<sup>2)</sup> for the max. tightening torques please observe the manufacturer's information on the used fittings and the general information on page 64

# Dimensions, size 250

Before finalising your design please request a certified installation drawing. Dimensions in inches (mm).

## Series 3

Example: SAE with N00 (for U99 dimensions, see page 61)  
pressure control; for exact dimensions of control devices see separate data sheets

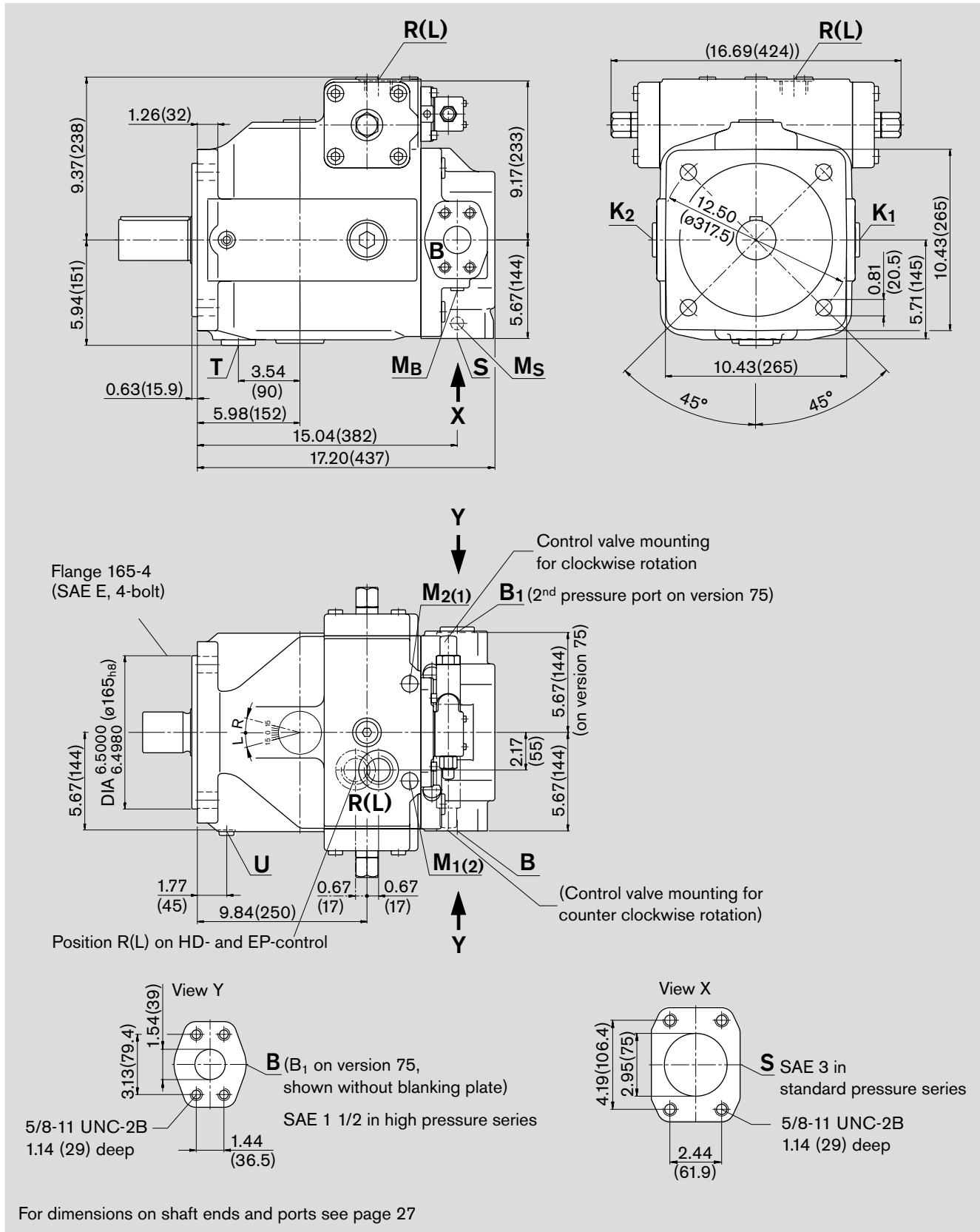

For dimensions on shaft ends and ports see page 27

# Dimensions, size 250

Before finalising your design please request a certified installation drawing. Dimensions in inches (mm).

## Shaft ends

**K** Parallel keyed shaft to ISO 3019-1, SAE F

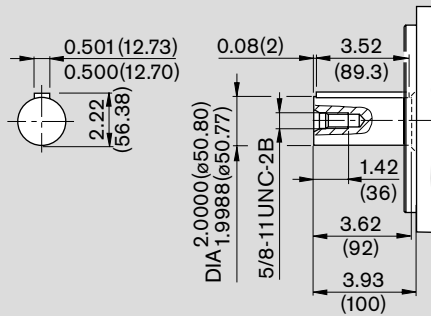

**S** Splined shaft to ISO 3019-1, SAE F  
50-4 (2 in, 8/16 DP; 15T<sup>1</sup>)

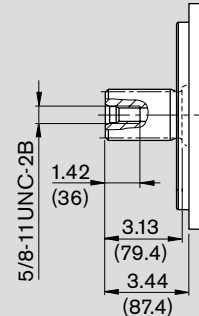

## Ports

max. tightening torque <sup>2)</sup>

S	Suction port (standard pressure series)	SAE J518	3 in	
	Mounting bolts	ISO 68	5/8-11UNC-2B; 1.14(29) deep <sup>2)</sup>	
K <sub>1</sub> , K <sub>2</sub>	Flushing port	ISO 11926	1 5/8-12UN-2B; 0.79(20) deep (plugged)	700 lb-ft (960 Nm)
T	Drain	ISO 11926	1 5/8-12UN-2B; 0.79(20) deep (plugged)	700 lb-ft (960 Nm)
M <sub>B</sub>	Gauge port outlet pressure	ISO 11926	7/16-20UNF-2B; 0.39(10) deep (plugged)	29 lb-ft (40 Nm)
M <sub>S</sub>	Gauge port suction pressure	ISO 11926	7/16-20UNF-2B; 0.39(10) deep (plugged)	29 lb-ft (40 Nm)
R(L)	Fill + air bleed (case drain port)	ISO 11926	1 5/8-12UN-2B; 0.79(20) deep	700 lb-ft (960 Nm)
U	Flushing port	ISO 11926	7/16-20UNF-2B; 0.39(10) deep (plugged)	29 lb-ft (40 Nm)
M <sub>1</sub> , M <sub>2</sub>	Gauge port control chamber pressure	DIN 3852	M18x1,5; 0.47(12) deep (plugged)	102 lb-ft (140 Nm)

### on version 63

B	Pressure port (high pressure series)	SAE J518	1 1/2 in	
	Mounting bolts	ISO 68	5/8-11UNC-2B; 1.14(29) deep <sup>2)</sup>	
B <sub>1</sub>	Additional port	ISO 11926	1 5/8-12UN-2B; 0.79(20) deep (plugged)	700 lb-ft (960 Nm)

### on version 75

B	Pressure port (high pressure series)	SAE J518	1 1/2 in	
	Mounting bolts	ISO 68	5/8-11UNC-2B; 1.14(29) deep <sup>2)</sup>	
B <sub>1</sub>	2 <sup>nd</sup> pressure port (high pressure series)	SAE J518	1 1/2 in (closed with blanking plate)	
	Mounting bolts	ISO 68	5/8-11UNC-2B; 1.14(29) deep <sup>2)</sup>	

<sup>1)</sup> ANSI B92.1a–1976, 30° pressure angle, flat base, flank centering, fit class 5

<sup>2)</sup> for the max. tightening torques please observe the manufacturer's information on the used fittings and the general information on page 64

# Dimensions, size 355

Before finalising your design please request a certified installation drawing. Dimensions in inches (mm).

## Series 3

Example: SAE with N00 (for U99 dimensions, see page 61)  
pressure control; for exact dimensions of control devices see separate data sheets)

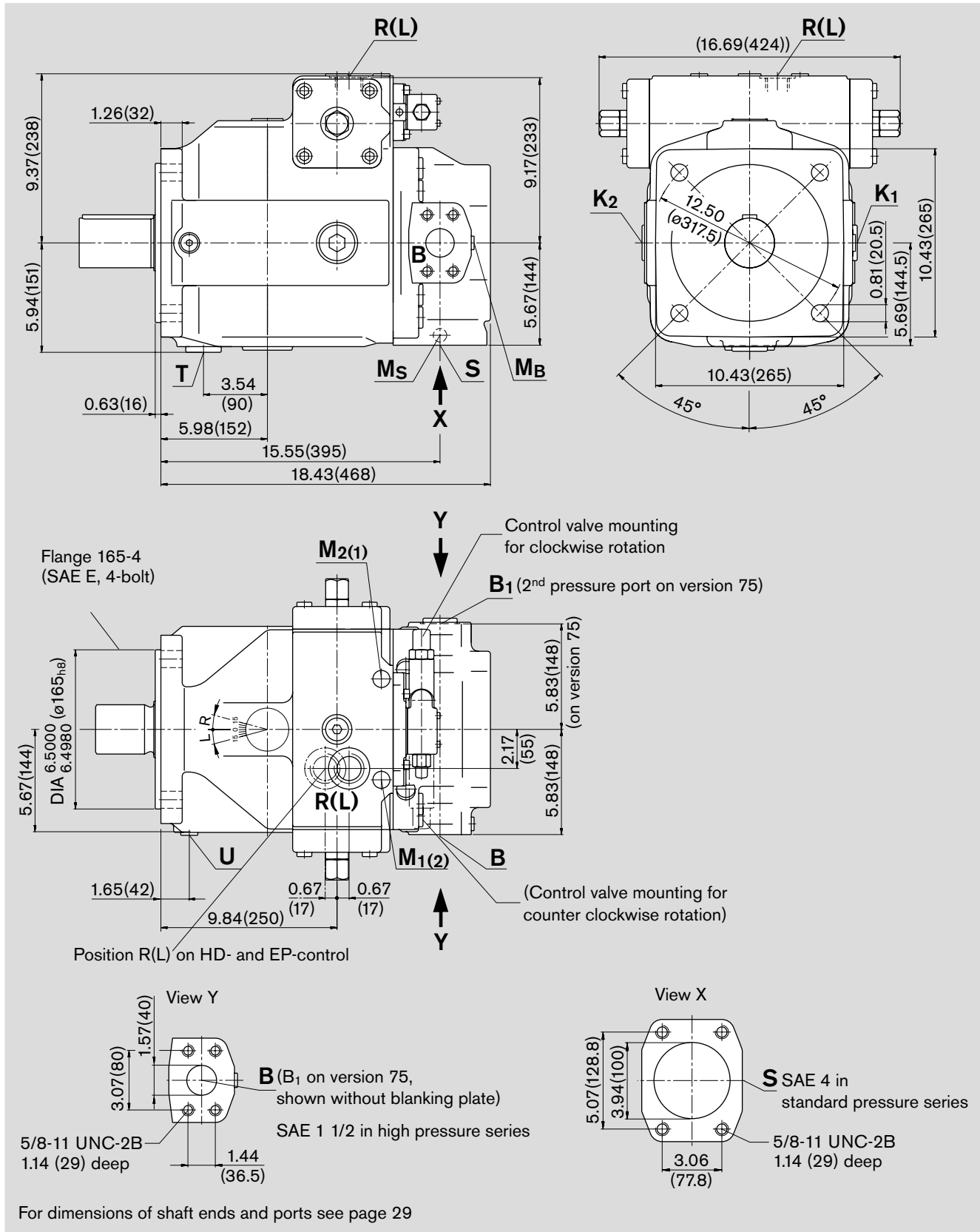

# Dimensions, size 355

Before finalising your design please request a certified installation drawing. Dimensions in inches (mm).

## Shaft ends

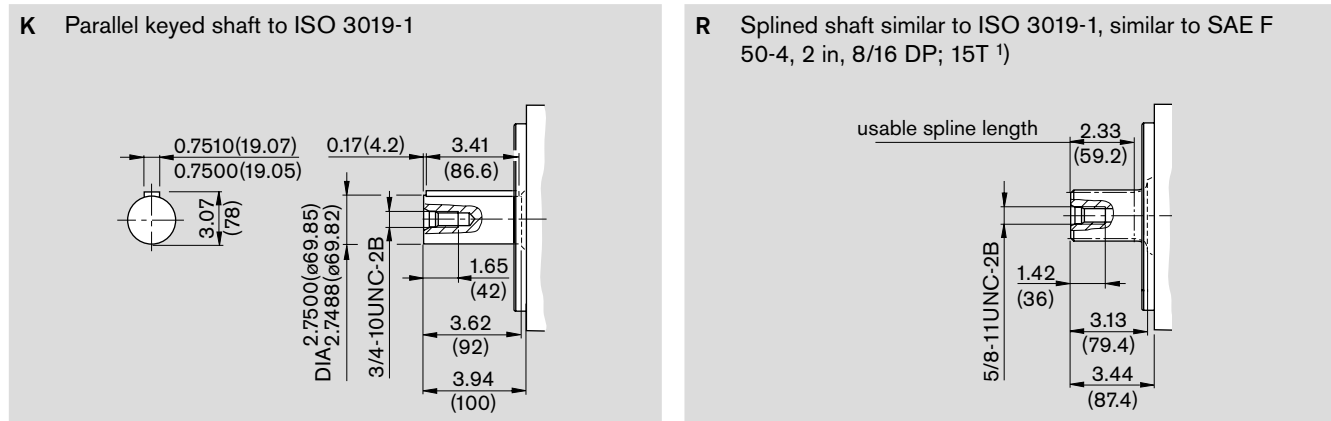

## Ports

max. tightening torque <sup>2)</sup>

S	Suction port (standard pressure series)	SAE J518	3 in	
	Mounting bolts	ISO 68	5/8-11UNC-2B; 1.14(29) deep <sup>2)</sup>	
K <sub>1</sub> , K <sub>2</sub>	Flushing port	ISO 11926	1 5/8-12UN-2B; 0.79(20) deep (plugged)	700 lb-ft (960 Nm)
T	Drain	ISO 11926	1 5/8-12UN-2B; 0.79(20) deep (plugged)	700 lb-ft (960 Nm)
M <sub>B</sub>	Gauge port outlet pressure	ISO 11926	7/16-20UNF-2B; 0.39(10) deep (plugged)	29 lb-ft (40 Nm)
M <sub>S</sub>	Gauge port suction pressure	ISO 11926	7/16-20UNF-2B; 0.39(10) deep (plugged)	29 lb-ft (40 Nm)
R(L)	Fill + air bleed (case drain port)	ISO 11926	1 5/8-12UN-2B; 0.79(20) deep	700 lb-ft (960 Nm)
U	Flushing port	ISO 11926	3/4-16UNF-2B; 0.59(15) deep (plugged)	117 lb-ft (160 Nm)
M <sub>1</sub> , M <sub>2</sub>	Gauge port control chamber pressure	DIN 3852	M18x1,5; 0.47(12) deep (plugged)	102 lb-ft (140 Nm)

### on version 63

B	Pressure port (high pressure series)	SAE J518	1 1/2 in	
	Mounting bolts	ISO 68	5/8-11UNC-2B; 1.14(29) deep <sup>2)</sup>	
B <sub>1</sub>	Additional port	ISO 11926	1 5/8-12UN-2B; 0.79(20) deep (plugged)	700 lb-ft (960 Nm)

### on version 75

B	Pressure port (high pressure series)	SAE J518	1 1/2 in	
	Mounting bolts	ISO 68	5/8-11UNC-2B; 1.14(29) deep <sup>2)</sup>	
B <sub>1</sub>	2 <sup>nd</sup> pressure port (high pressure series)	SAE J518	1 1/2 in (closed with blanking plate)	
	Mounting bolts	ISO 68	5/8-11UNC-2B; 1.14(29) deep <sup>2)</sup>	

<sup>1)</sup> ANSI B92.1a–1976, 30° pressure angle, flat base, flank centering, fit class 5

<sup>2)</sup> for the max. tightening torques please observe the manufacturer's information on the used fittings and the general information on page 64

# Dimensions, size 500

Before finalising your design please request a certified installation drawing. Dimensions in inches (mm).

## Series 3

Example: metric with N00  
pressure control; for exact dimensions of control devices see separate data sheets

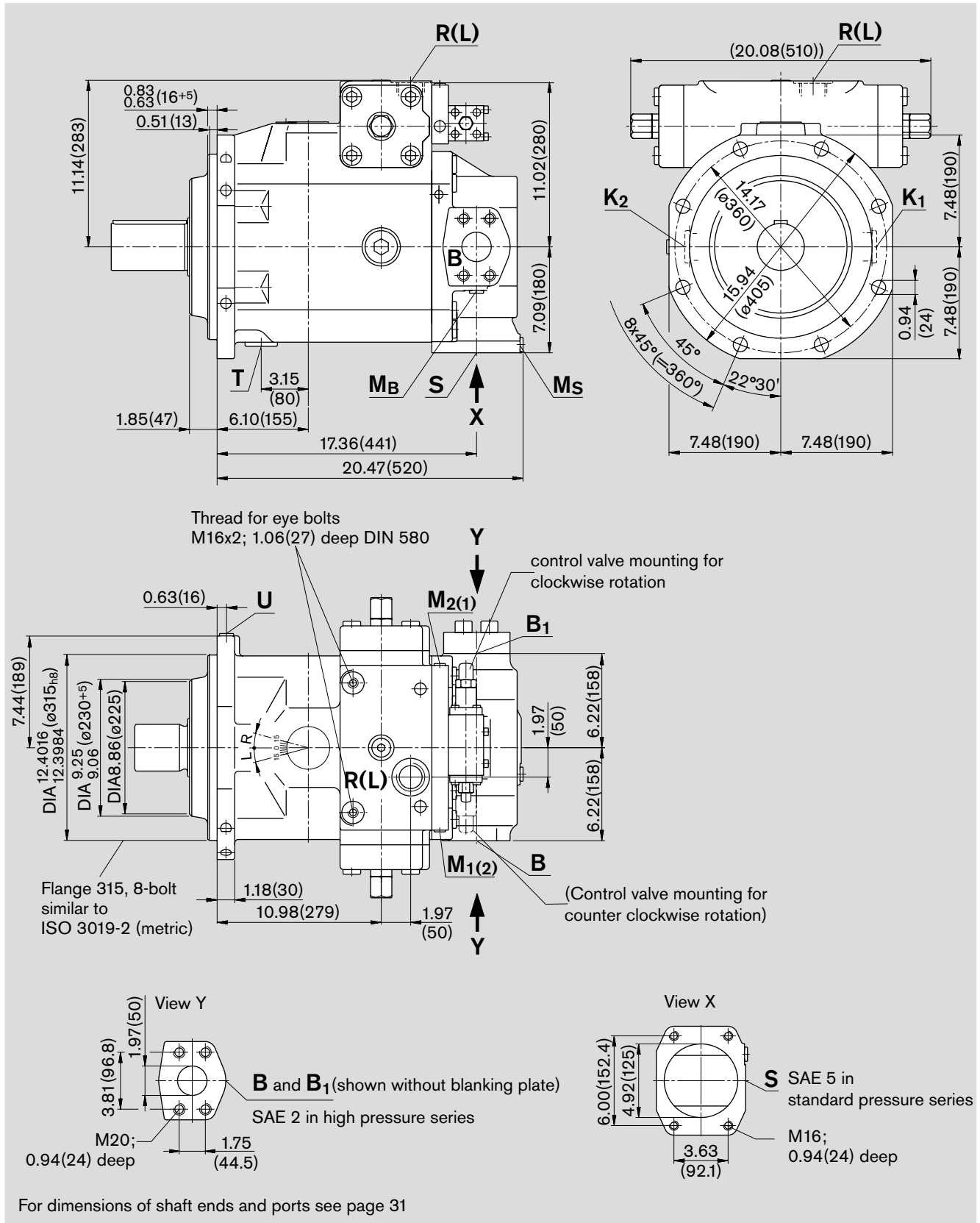

# Dimensions, size 500

Before finalising your design please request a certified installation drawing. Dimensions in inches (mm).

## Shaft ends

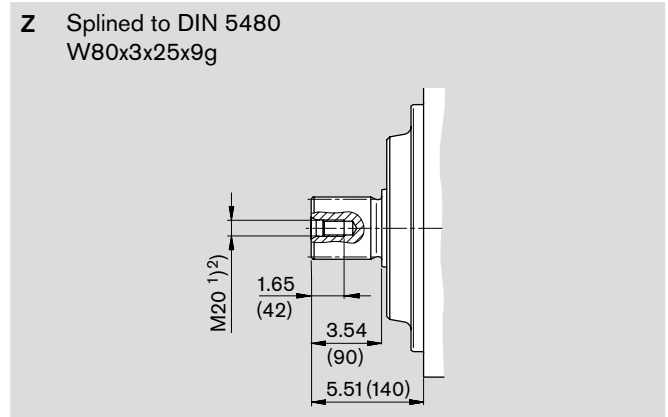
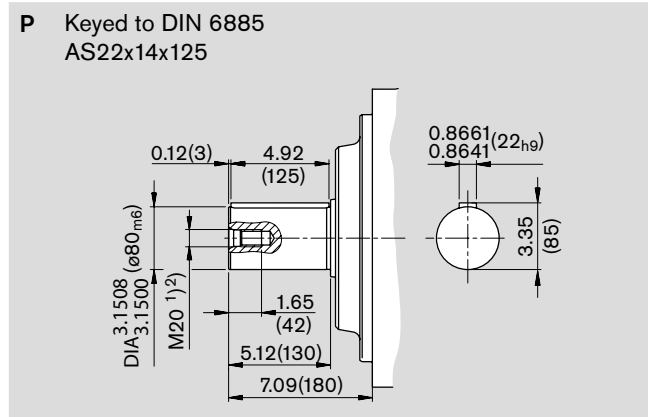

## Ports

max. tightening torque <sup>2)</sup>

S	Suction port (standard pressure series) Mounting bolts	SAE J518 <sup>3)</sup> DIN 13	5 in M16x2; 0.94(24) deep <sup>2)</sup>	
K <sub>1</sub> , K <sub>2</sub>	Flushing port	DIN 3852	M48x2; 0.87(22) deep (plugged)	700 lb-ft (960 Nm)
T	Drain	DIN 3852	M48x2; 0.87(22) deep (plugged)	700 lb-ft (960 Nm)
M <sub>B</sub>	Gauge port outlet pressure	DIN 3852	M18x1,5; 0.47(12) deep (plugged)	102 lb-ft (140 Nm)
M <sub>S</sub>	Gauge port suction pressure	DIN 3852	M18x1,5; 0.47(12) deep (plugged)	102 lb-ft (140 Nm)
R(L)	Fill + air bleed (case drain port)	DIN 3852	M48x2; 0.87(22) deep	700 lb-ft (960 Nm)
U	Flushing port	DIN 3852	M18x1,5; 0.47(12) deep (plugged)	102 lb-ft (140 Nm)
M <sub>1</sub> , M <sub>2</sub>	Gauge port control chamber pressure or dependent on control device	DIN 3852 DIN 3852	M18x1,5; 0.47(12) deep (plugged) M14x1,5; 0.47(12) deep (plugged)	102 lb-ft (140 Nm) 58 lb-ft (80 Nm)
B	Pressure port (high pressure series) Mounting bolts	SAE J518 <sup>3)</sup> DIN 13	2 in M20x2,5; 0.94(24) deep <sup>2)</sup>	
B <sub>1</sub>	2 <sup>nd</sup> pressure port (high pressure series) Mounting bolts	SAE J518 <sup>3)</sup> DIN 13	2 in (closed with blanking plate) M20x2,5; 0.94(24) deep <sup>2)</sup>	

<sup>1)</sup> Center bore to DIN 332 (thread to DIN 13)

<sup>2)</sup> for the max. tightening torques please observe the manufacturer's information on the used fittings and the general information on page 64

<sup>3)</sup> Caution: metric thread deviates from standard

# Dimensions, size 750

Before finalising your design please request a certified installation drawing. Dimensions in inches (mm).

## Series 3

Example: metric with N00 pressure control; for exact dimensions of control devices see separate data sheets

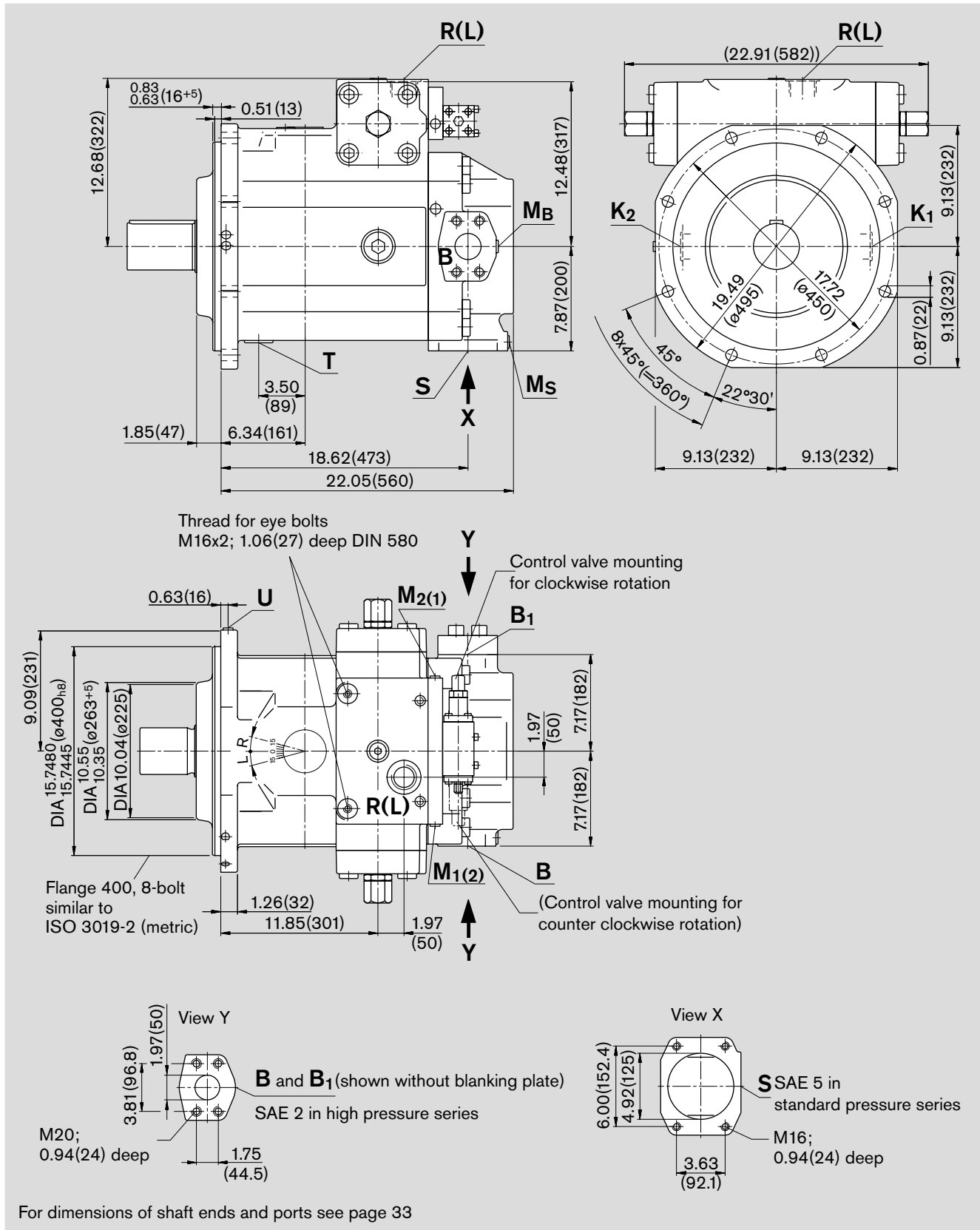



# Dimensions, size 750

Before finalising your design please request a certified installation drawing. Dimensions in inches (mm).

## Shaft ends

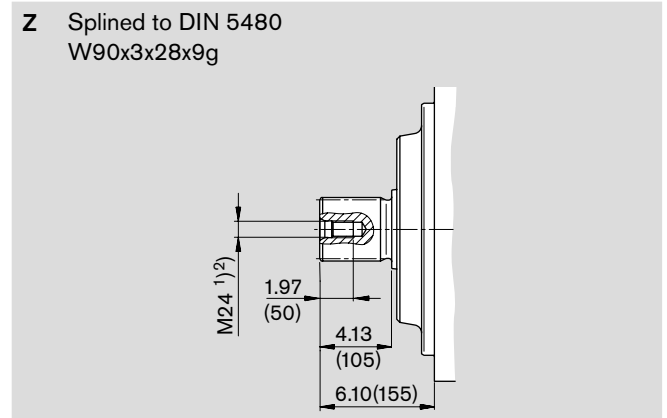
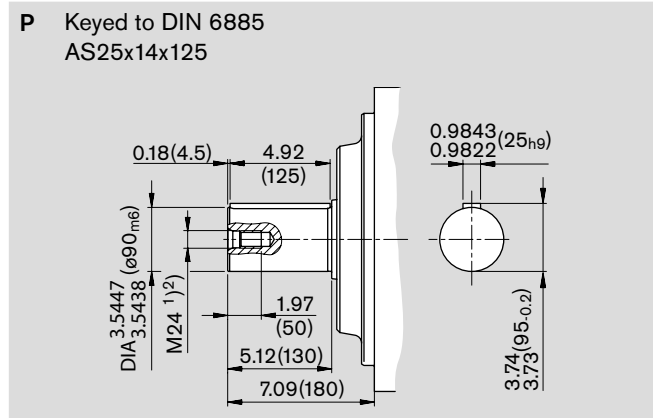

## Ports

max. tightening torques <sup>2)</sup>

S	Suction port (standard pressure series)	SAE J518 <sup>3)</sup>	5 in	
	Mounting bolts	DIN 13	M16x2; 0.94(24) deep <sup>2)</sup>	
K <sub>1</sub> , K <sub>2</sub>	Flushing port	DIN 3852	M48x2; 0.79(20) deep (plugged)	700 lb-ft (960 Nm)
T	Drain	DIN 3852	M48x2; 0.79(20) deep (plugged)	700 lb-ft (960 Nm)
M <sub>B</sub>	Gauge port outlet pressure	DIN 3852	M18x1,5; 0.47(12) deep (plugged)	102 lb-ft (140 Nm)
M <sub>S</sub>	Gauge port suction pressure	DIN 3852	M18x1,5; 0.47(12) deep (plugged)	102 lb-ft (140 Nm)
R(L)	Fill + air bleed (case drain port)	DIN 3852	M48x2; 0.79(20) deep	700 lb-ft (960 Nm)
U	Flushing port	DIN 3852	M18x1,5; 0.47(12) deep (plugged)	102 lb-ft (140 Nm)
M <sub>1</sub> , M <sub>2</sub>	Gauge port control chamber press. or dependent on control device	DIN 3852	M18x1,5; 0.47(12) deep (plugged)	102 lb-ft (140 Nm)
		DIN 3852	M14x1,5; 0.47(12) deep (plugged)	58 lb-ft (80 Nm)
B	Pressure port (high pressure series)	SAE J518 <sup>3)</sup>	2 in	
	Mounting bolts	DIN 13	M20x2,5; 0.94(24) deep <sup>2)</sup>	
B <sub>1</sub>	2 <sup>nd</sup> pressure port (high pressure series)	SAE J518 <sup>3)</sup>	2 in (closed with blanking plate)	
	Mounting bolts	DIN 13	M20x2,5; 0.94(24) deep <sup>2)</sup>	

<sup>1)</sup> Center bore to DIN 332 (thread to DIN 13)

<sup>2)</sup> for the max. tightening torques please observe the manufacturer's information on the used fittings and the general information on page 64

<sup>3)</sup> Caution: metric thread deviates from standard

# Dimensions, size 750 with boost pump (Impeller)

Before finalising your design please request a certified installation drawing. Dimensions in inches (mm).

## Series 3

Example: metric with N00

pressure control; for exact dimensions of control devices see separate data sheets

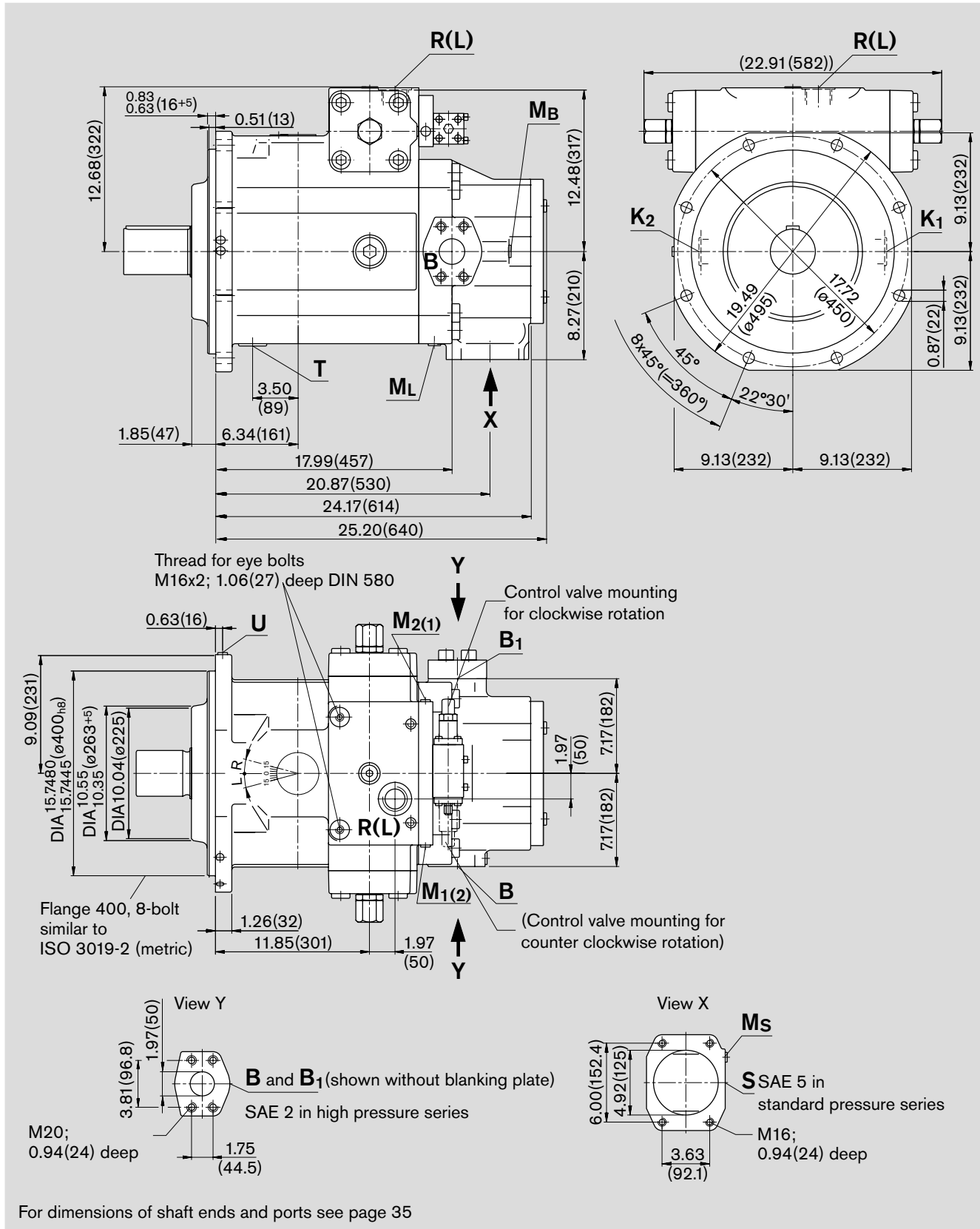

For dimensions of shaft ends and ports see page 35

# Dimensions, size 750 with boost pump (Impeller)

Before finalising your design please request a certified installation drawing. Dimensions in inches (mm).

## Shaft ends

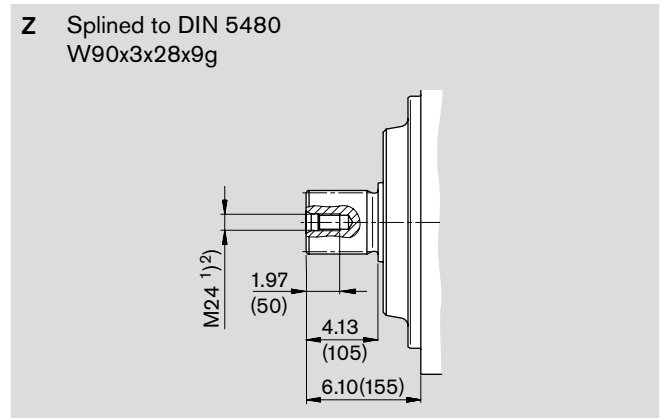
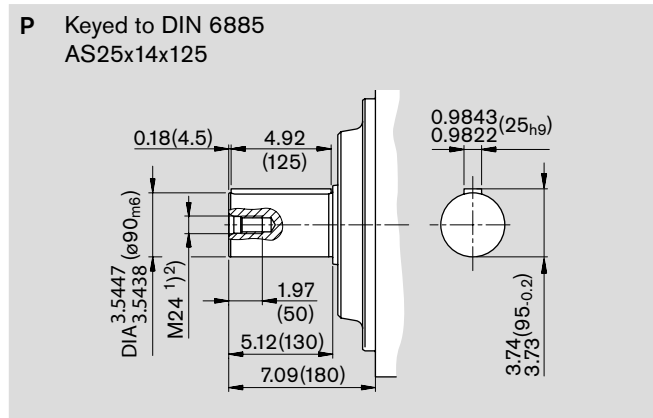

## Ports

			max. tightening torque <sup>2)</sup>
S	Suction port (standard pressure series)	SAE J518 <sup>3)</sup> 5 in	
	Mounting bolts	DIN 13 M16x2; 0.94(24) deep <sup>2)</sup>	
K <sub>1</sub> , K <sub>2</sub>	Flushing port	DIN 3852 M48x2; 0.79(20) deep (plugged)	700 lb-ft (960 Nm)
T	Drain	DIN 3852 M48x2; 0.79(20) deep (plugged)	700 lb-ft (960 Nm)
M <sub>B</sub>	Gauge port outlet pressure	DIN 3852 M18x1,5; 0.47(12) deep (plugged)	102 lb-ft (140 Nm)
M <sub>S</sub>	Gauge port suction pressure	DIN 3852 M18x1,5; 0.47(12) deep (plugged)	102 lb-ft (140 Nm)
M <sub>L</sub>	Gauge port boost pressure	DIN 3852 M18x1,5; 0.47(12) deep (plugged)	102 lb-ft (140 Nm)
R(L)	Fill + air bleed (case drain port)	DIN 3852 M48x2; 0.79(20) deep	700 lb-ft (960 Nm)
U	Flushing port	DIN 3852 M18x1,5; 0.47(12) deep (plugged)	102 lb-ft (140 Nm)
M <sub>1</sub> , M <sub>2</sub>	Gauge port control chamber press. or dependent on control device	DIN 3852 M18x1,5; 0.47(12) deep (plugged)	102 lb-ft (140 Nm)
		DIN 3852 M14x1,5; 0.47(12) deep (plugged)	58 lb-ft (80 Nm)
B	Pressure port (high pressure series)	SAE J518 <sup>3)</sup> 2 in	
	Mounting bolts	DIN 13 M20x2,5; 0.94(24) deep <sup>2)</sup>	
B <sub>1</sub>	2 <sup>nd</sup> pressure port (high pressure series)	SAE J518 <sup>3)</sup> 2 in (closed with blanking plate)	
	Mounting bolts	DIN 13 M20x2,5; 0.94(24) deep <sup>2)</sup>	

<sup>1)</sup> Center bore to DIN 332 (thread to DIN 13)

<sup>2)</sup> for the max. tightening torques please observe the manufacturer's information on the used fittings and the general information on page 64

<sup>3)</sup> Caution: metric thread deviates from standard

# Dimensions, size 1000

Before finalising your design please request a certified installation drawing. Dimensions in inches (mm).

## Series 3

Example: metric with N00

pressure control; for exact dimensions of control devices see separate data sheets

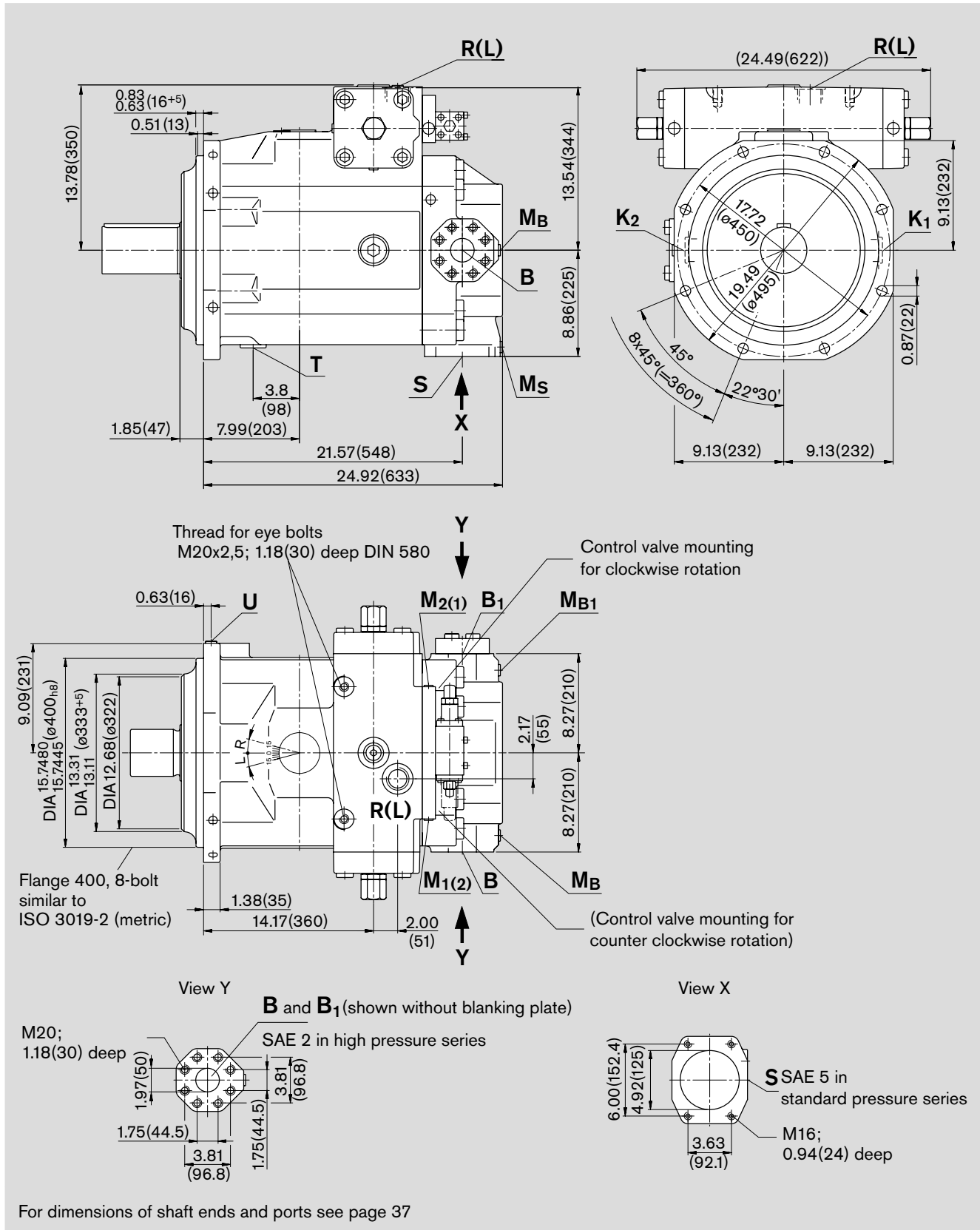

# Dimensions, size 1000

Before finalising your design please request a certified installation drawing. Dimensions in inches (mm).

## Shaft ends

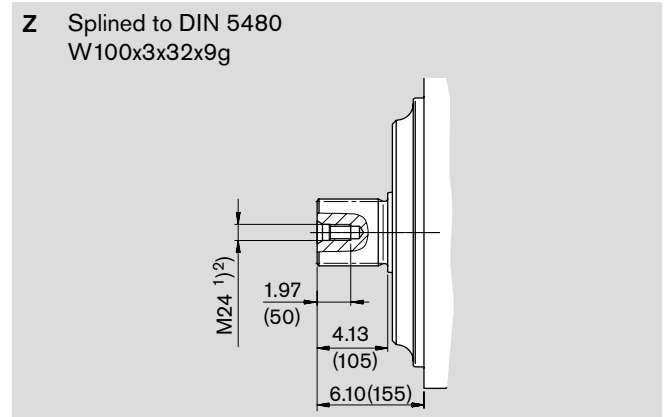
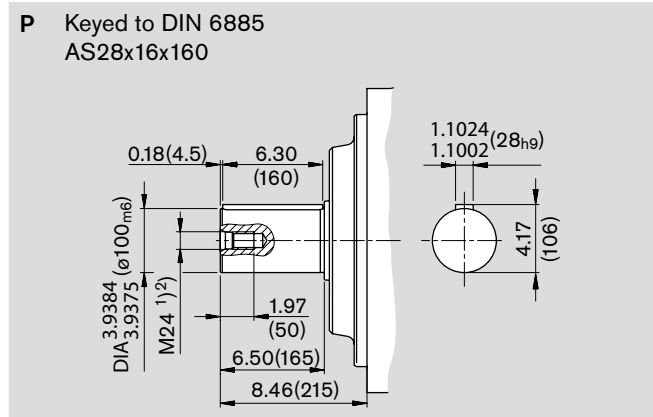

## Ports

Port	Description	SAE J518 <sup>3)</sup>	DIN	Depth	max. tightening torque <sup>2)</sup>
S	Suction port (standard pressure series)	5 in	DIN 13	M16x2; 0.94(24) deep <sup>2)</sup>	
K <sub>1</sub> , K <sub>2</sub>	Flushing port		DIN 3852	M48x2; 0.79(20) deep (plugged)	700 lb-ft (960 Nm)
T	Drain		DIN 3852	M48x2; 0.79(20) deep (plugged)	700 lb-ft (960 Nm)
M <sub>B</sub> , M <sub>B1</sub>	Gauge port outlet pressure		DIN 3852	M18x1,5; 0.47(12) deep (plugged)	102 lb-ft (140 Nm)
M <sub>S</sub>	Gauge port suction pressure		DIN 3852	M18x1,5; 0.47(12) deep (plugged)	102 lb-ft (140 Nm)
R(L)	Fill + air bleed (case drain port)		DIN 3852	M48x2; 0.79(20) deep	700 lb-ft (960 Nm)
U	Flushing port		DIN 3852	M18x1,5; 0.47(12) deep (plugged)	102 lb-ft (140 Nm)
M <sub>1</sub> , M <sub>2</sub>	Gauge port control chamber press. or dependent on control device		DIN 3852	M18x1,5; 0.47(12) deep (plugged)	102 lb-ft (140 Nm)
			DIN 3852	M14x1,5; 0.47(12) deep (plugged)	58 lb-ft (80 Nm)
B	Pressure port (high pressure series)	2 in	DIN 13	M20x2,5; 1.18(30) deep <sup>2)</sup>	
B <sub>1</sub>	2 <sup>nd</sup> pressure port (high pressure series)	2 in (closed with blanking plate)	DIN 13	M20x2,5; 1.18(30) deep <sup>2)</sup>	

<sup>1)</sup> Center bore to DIN 332 (thread to DIN 13)

<sup>2)</sup> for the max. tightening torques please observe the manufacturer's information on the used fittings and the general information on page 64

<sup>3)</sup> Caution: metric thread deviates from standard

# Through drive

The axial piston unit (A)A4VSO can be equipped with a through drive, as shown in the type code on page 4. The through drive execution is designated by the code K/U 15...99.

We recommend, that no more than three pumps be coupled together.

## Permissible input and through drive torques

Size		40	71	125	180	250	355	500	750	1000		
<b>Splined shaft</b>												
Max. perm. total input torque at shaft of pump 1 (Pump 1 + pump 2)		$T_{tot\ max}$	lb-ft Nm	329 (446)	583 (790)	1027 (1392)	1478 (2004)	2052 (2782)	2133 (2890)	4105 (5566)	6157 (8348)	8209 (11130)
<b>A</b> Perm. through drive torque	$T_{D1\ max}$	lb-ft Nm	164 (223)	291 (395)	513 (696)	739 (1002)	1026 (1391)	1457 (1976)	2052 (2783)	3078 (4174)	4104 (5565)	
	$T_{D2\ max}$	lb-ft Nm	164 (223)	291 (395)	513 (696)	739 (1002)	1026 (1391)	675 (914)	2052 (2783)	3078 (4174)	4104 (5565)	
<b>B</b> Perm. through drive torque	$T_{D1\ max}$	lb-ft Nm	164 (223)	291 (395)	513 (696)	739 (1002)	1026 (1391)	675 (914)	2052 (2783)	3078 (4174)	4104 (5565)	
	$T_{D2\ max}$	lb-ft Nm	164 (223)	291 (395)	513 (696)	739 (1002)	1026 (1391)	1457 (1976)	2052 (2783)	3078 (4174)	4104 (5565)	
<b>Keyed shaft</b>												
Max. perm. total input torque at shaft of pump 1 (Pump 1 + pump 2)		$T_{tot\ max}$	lb-ft Nm	329 (446)	583 (790)	1027 (1392)	1479 (2004)	1889 (2560)	2917 (3952)	3835 (5200)	5541 (7513)	6965 (9444)
<b>A</b> Perm. through drive torque	$T_{D1\ max}$	lb-ft Nm	164 (223)	291 (395)	513 (696)	739 (1002)	1026 (1391)	1457 (1976)	2052 (2783)	3078 (4174)	4104 (5565)	
	$T_{D2\ max}$	lb-ft Nm	164 (223)	291 (395)	513 (696)	739 (1002)	863 (1169)	1457 (1976)	1783 (2417)	2463 (3339)	2860 (3879)	
<b>B</b> Perm. through drive torque	$T_{D1\ max}$	lb-ft Nm	164 (223)	291 (395)	513 (696)	739 (1002)	863 (1169)	1457 (1976)	1783 (2417)	2463 (3339)	2860 (3879)	
	$T_{D2\ max}$	lb-ft Nm	164 (223)	291 (395)	513 (696)	739 (1002)	1026 (1391)	1457 (1976)	2052 (2783)	3078 (4174)	4104 (5565)	

## Distribution of torques

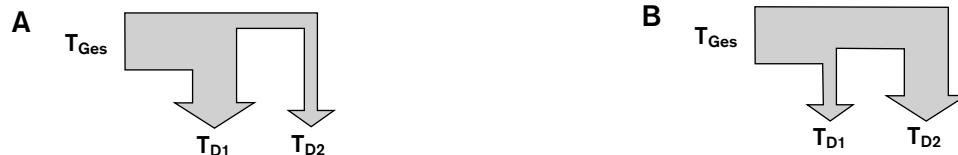

## Single pump with through drive

If no further pumps are factory-mounted the simple type code is sufficient.

### included in this case are:

- on all through drives except K/U 99
- shaft coupler, mounting screws, seal and if required an adapter flange
- on K/U 99
- with through drive shaft, without shaft coupler, without adapter flange; unit is closed with pressure tight cover.

## Universal through drive

On pump sizes 125...355 all through drives are supplied as universal through drives „U“ .

These have the advantage, that they can be adapted later on.

Simply by exchanging the adapter flange and the shaft coupler it is possible to convert the through drive option. The conversion sets must be ordered separately, see RE 95581.

## Combination pumps

Independent circuits are available for the user when further pumps are built on.

- If the combination consists of **2 Rexroth axial piston pumps**, and if this must be **factory mounted**, the two individual type codes must be joined by a „+“ .

Ordering example:

AA4VSO 125 DR / 30 R – PSD75U16 + AA4VSO 71 DR / 10 R – PSD63N00

- If a **gear** or a radial piston pump must be **factory mounted** as the second pump please consult us.

# Overview of (A)A4VSO through drive options

Through drive - (A)A4VSO			Mounting option 2. pump					Through drive
Flange	Coupler for splined shaft <sup>6)</sup>	Code	(A)A4VSO/G size (shaft)	(A)A4CSG size (shaft)	(A)A10V(S)O/31(2) <sup>5)</sup> size (shaft)	A10V(S)O/52(3) size (shaft)	Gear and vane pump (shaft) cm <sup>3</sup> /rev	available on size
<b>Flange SAE J 744 (ISO 3019-1)</b>								
82-2 (A) <sup>1)</sup>	16-4 (5/8in, 9T) <sup>3)</sup>	K/U01	–	–	–	–	AZ-PF-1X-(R) 004...028 <sup>4)</sup> PGH2/3(R) 5...16	40...750
	19-4 (3/4in, 11T) <sup>3)</sup>	K/U52	–	–	18 (S)/31	10, 18 (S)	–	40...355
101-2 (B) <sup>1)</sup>	22-4 (7/8in, 13T) <sup>3)</sup>	K/U68	–	–	28 (S)/31	28 (S)	AZ-PN-1X-(D) 020...036 <sup>4)</sup>	40...500
	25-4 (1in, 15T) <sup>3)</sup>	K/U04	–	–	45 (S)/31	45 (S)	PGH4-3X(R) 20...50	40...500
127-2 (C) <sup>1)</sup>	32-4 (1 1/4in, 14T) <sup>3)</sup>	K/U07	–	–	71 (S)/31	–	PVV/Q4/5(J) 69...193	71...500
	38-4 (1 1/2in, 17T) <sup>3)</sup>	K/U24	–	–	100 (S)/31	85 (S)	PGH5-3X(R) 63...250	125...500
127-4(C) <sup>1)</sup>	32-4 (1 1/4in, 14T) <sup>3)</sup>	K/U15	40 (S)	–	71(S)32	–	–	40...355
	38-4 (1 1/2in, 17T) <sup>3)</sup>	K/U16	71 (S)	–	–	–	–	71...355
152-4(D) <sup>1)</sup>	44-4 (1 3/4in, 13T) <sup>3)</sup>	K/U17	125 (S)	–	140 (S)/31/32	–	–	125...500
	50-4 (2in, 15T) <sup>3)</sup>	U78	180 (S)	–	–	–	–	180...355
165-4(E) <sup>1)</sup>	50-4 (2in, 15T) <sup>3)</sup>	U18	250 (S)	250 (S)	–	–	–	250, 355
			355 (R)	355 (R)	–	–	–	355
<b>Flange ISO 3019-2 (metric)</b>								
80, 2-bolt	19-4 (3/4in, 11T) <sup>3)</sup>	KB2	–	–	18 (S)/31	10 (S)	–	in preparation
100, 2-bolt	22-4 (7/8in, 13T) <sup>3)</sup>	KB3	–	–	28 (S)/31	–	–	in preparation
	25-4 (1in, 15T) <sup>3)</sup>	KB4	–	–	45 (S)/31	–	–	500
125, 2-bolt	32-4 (1 1/4in, 14T) <sup>3)</sup>	KB5	–	–	71 (S)/31	–	–	in preparation
	38-4(1 1/2in, 17T) <sup>3)</sup>	KB6	–	–	100 (S)/31	–	–	in preparation
125, 4-bolt	W 32x2x14x9g <sup>2)</sup>	K31	40 (Z)	–	–	–	–	500
140, 4-bolt	W 40x2x18x9g <sup>2)</sup>	K33	71 (Z)	–	–	–	–	500, 750
160, 4-bolt	W 50x2x24x9g <sup>2)</sup>	K34	125 (Z)	–	–	–	–	500, 750
			180 (Z)	–	–	–	–	500, 750
	32-4 (1 1/4in, 14T) <sup>3)</sup>	KB8	–	–	71 (S)/32	–	–	in preparation
180, 4-bolt	44-4 (1 3/4in, 13T) <sup>3)</sup>	KB7	–	–	140 (S)/31/32	–	–	500
	38-4 (1 1/2in, 17T) <sup>3)</sup>	KB9	–	–	100 (S)/32	–	–	in preparation
224, 4-bolt	W 60x2x28x9g <sup>2)</sup>	K35	250 (Z)	250 (Z)	–	–	–	500, 750
	W 70x3x22x9g <sup>2)</sup>	K77	355 (Z)	355 (Z)	–	–	–	500
315, 8-bolt	W 80x3x25x9g <sup>2)</sup>	K43	500 (Z)	500 (Z)	–	–	–	500, 750
400, 8-bolt	W 90x3x28x9g <sup>2)</sup>	K76	750 (Z)	750 (Z)	–	–	–	750
	W 100x3x32x9g <sup>2)</sup>	K88	1000 (Z)	–	–	–	–	1000
Dia 63-4, metr.	Keyed dia 25	K/U57	–	–	–	–	R4	40 a. 71

<sup>1)</sup> 2 = 2-bolt, 4 = 4-bolt

<sup>2)</sup> to DIN 5480

<sup>3)</sup> Splined shafts acc. to ISO 3019-1 (SAEJ744)

<sup>4)</sup> Rexroth recommends special versions of the gear pumps. Please consult us.

<sup>5)</sup> If a through drive for an A10V(S)O with R-shaft is desired, please consult us.

<sup>6)</sup> Keyed shaft on through drive code K/U57

# Permissible mass moment of inertia

referred to the mounting flange of the main pump

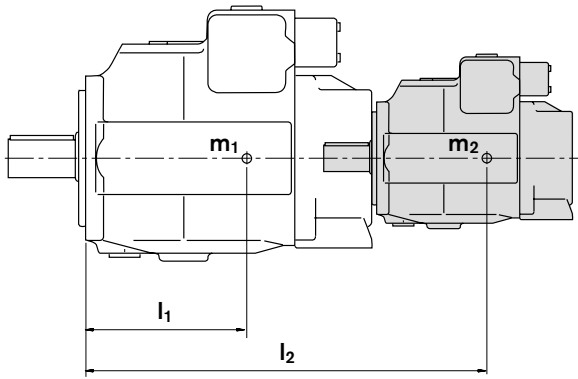

$m_1, m_2$  lbs (kg) Weight of pump

$l_1, l_2$  in (mm) Distance center of gravity

$$T_m = m_1 \cdot l_1 \cdot \frac{1}{12} + m_2 \cdot l_2 \cdot \frac{1}{12} \quad [\text{lb-ft}]$$

$$(T_m = m_1 \cdot l_1 \cdot \frac{1}{102} + m_2 \cdot l_2 \cdot \frac{1}{102} \quad [\text{Nm}])$$

Size			40	71	125	180	250	355	500	750	1000
Perm. mass moment of inertia	$T_{m \text{ perm.}}$	lb-ft (Nm)	1327 (1800)	1475 (2000)	3098 (4200)	3098 (4200)	6859 (9300)	6859 (9300)	11506 (15600)	14382 (19500)	14382 (19500)
Perm. mass moment at dynam. acceleration of $10 \text{ g} \hat{=} 98,1 \text{ m/sec}^2$	$T_{m \text{ perm.}}$	lb-ft (Nm)	132 (180)	148 (200)	310 (420)	310 (420)	686 (930)	686 (930)	1151 (1560)	1438 (1950)	1438 (1950)
Weight (A4VSO...DR)	$m$	lbs (kg)	86 (39)	117 (53)	194 (88)	225 (102)	406 (184)	456 (207)	705 (320)	1041 (460)	1333 (605)
Distance center of gravity	$l_1$	in (mm)	4.72 (120)	5.51 (140)	6.69 (170)	7.08 (180)	8.26 (210)	8.66 (220)	9.05 (230)	10.23 (260)	11.41 (290)



# Dimensions combination pumps

Before finalising your design please request a certified installation drawing. Dimensions in inches (mm).

(A)A4VSO + (A)A4VSO

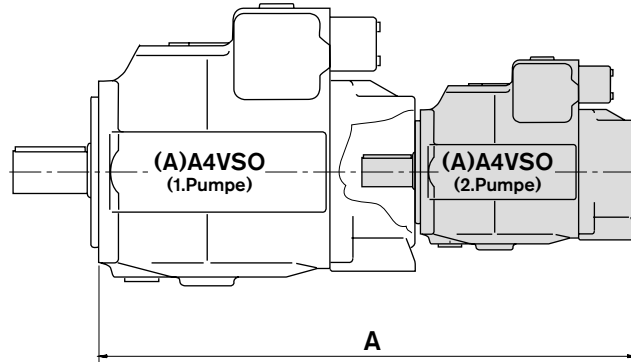

Overall length A

(A)A4VSO (1. pump)	(A)A4VSO..DR..N00 (2. pump)								
	Size 40	Size 71	Size 125	Size 180	Size 250	Size 355	Size 500	size 750	Size 1000
Size 40	22.17(563)	-	-	-	-	-	-	-	-
Size 71	23.27(591)	24.41(620)	-	-	-	-	-	-	-
Size 125	25.16(639)	26.30(668)	29.17(741)	-	-	-	-	-	-
Size 180	26.10(663)	27.24(692)	30.12(765)	31.89(810)	-	-	-	-	-
Size 250	28.46(723)	29.61(752)	31.97(812)	33.78(858)	36.14(918)	-	-	-	-
Size 355	29.61(752)	30.75(781)	33.11(841)	34.92(887)	37.28(947)	38.44(976)	-	-	-
Size 500	30.35(771)	31.50(800)	33.86(860)	34.65(880)	38.43(976)	39.57(1005)	43.70(1110)	-	-
Size 750	32.32(821)	33.46(850)	35.83(910)	36.61(930)	40.39(1026)	41.54(1055)	45.67(1160)	47.80(1214)	-
Size 1000	*	*	*	*	*	*	*	*	53.86(1368)

\* on request

# Dimensions combination pumps

Before finalising your design please request a certified installation drawing. Dimensions in inches (mm).

(A)A4VSO + (A)A10VSO

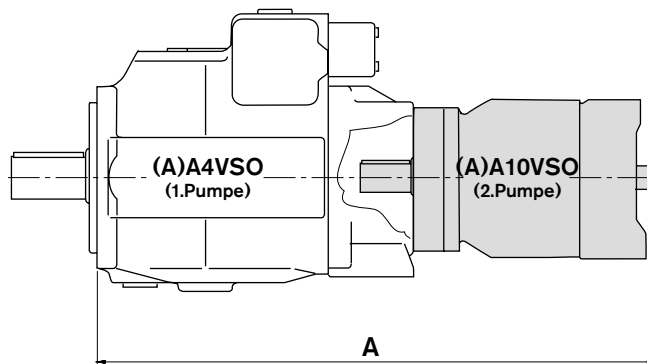

## Overall length A

(A)A4VSO (1. pump)	(A)A10VSO.../31 (2. pump)					
	Size 18	Size 28	Size 45	Size 71	Size 100	Size 140
Size 40	18.11(460)	19.61(498)	20.31(516)	–	–	–
Size 71	20.16(512)	20.87(530)	21.57(548)	22.83(580)	–	–
Size 125	22.28(566)	22.72(577)	23.43(595)	24.72(628)	27.56(700)	–
Size 180	23.23(590)	23.66(601)	24.37(619)	25.67(652)	28.50(724)	29.33(745)
Size 250	25.59(650)	26.02(661)	26.73(679)	28.03(712)	30.87(784)	31.18(792)
Size 355	*	*	27.87(708)	29.17(741)	*	32.32(821)
Size 500	27.56(700)	27.99(711)	28.70(729)	30.08(764)	33.74(857)	34.17(868)
Size 750	29.53(750)	29.96(761)	30.67(779)	31.97(812)	35.71(907)	36.10(917)
Size 1000	*	*	*	*	*	*

\* on request

# Dimensions through drives

Before finalising your design please request a certified installation drawing. Dimensions in inches (mm).

**K15** Flange 127-4 to ISO 3019-1 (SAE C, 4-bolt)  
 Shaft coupler 32-4 to ISO 3019-1 (SAE C, 1 1/4 in, 12/24 DP; 14 T)<sup>3)</sup>  
 for mounting an AA4VSO/G 40 splined shaft

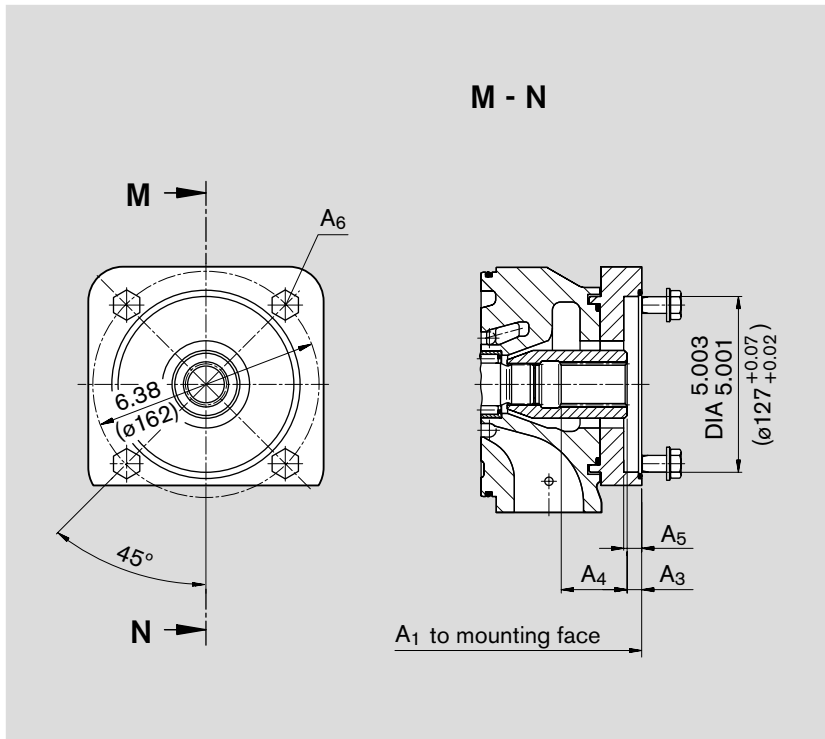

Size	A <sub>1</sub>	A <sub>3</sub>	A <sub>4</sub>
40	11.61 (295)	0.51 (13)	1.73 (44)
71	12.72 (323)	0.41 (10.4)	1.87 (47.5)

Size	A <sub>5</sub>	A <sub>6</sub> <sup>2)</sup>
40	0.51 (13)	M12
71	0.51 (13)	M12

**U15** Flange 127-4 to ISO 3019-1 (SAE C, 4-bolt)  
 Shaft coupler 32-4 to ISO 3019-1 (SAE C, 1 1/4 in, 12/24 DP; 14 T)<sup>3)</sup>  
 for mounting an AA4VSO/G 40 splined shaft

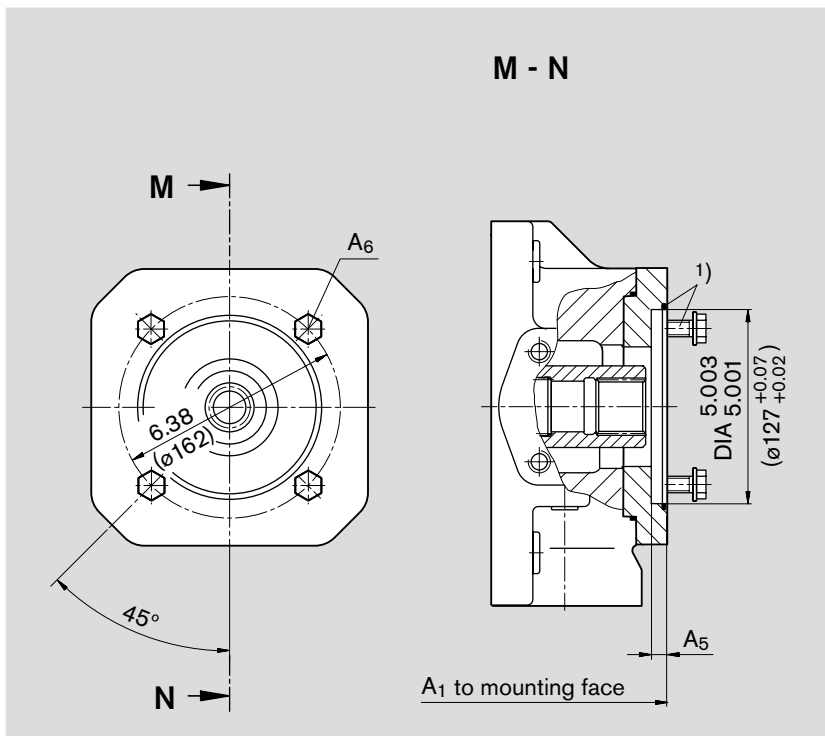

Size	A <sub>1</sub>	A <sub>5</sub>	A <sub>6</sub> <sup>2)</sup>
125	14.61 (371)	0.51 (13)	M12
180	15.55 (395)	0.51 (13)	M12
250	17.91 (455)	0.51 (13)	M12
355	19.06 (484)	0.51 (13)	M12

Further dimensions on request

1) Mounting screws and O-ring seal are included with supply  
 2) Thread to DIN 13, for the max. tightening torques observe the general information on page 64  
 3) To ANSI B92.1a-1976, 30° pressure angle, flat base, flank centering, fit class 5

# Dimensions through drives

Before finalising your design please request a certified installation drawing. Dimensions in inches (mm).

**K16** Flange 127-4 to ISO 3019-1 (SAE C, 4-bolt)  
 Shaft coupler 38-4 to ISO 3019-1 (SAE C-C, 1 1/2 in, 12/24 DP; 17T)<sup>3)</sup>  
 for mounting an AA4VSO/G 71 splined shaft  
 only on mainpump AA4VSO/G 71

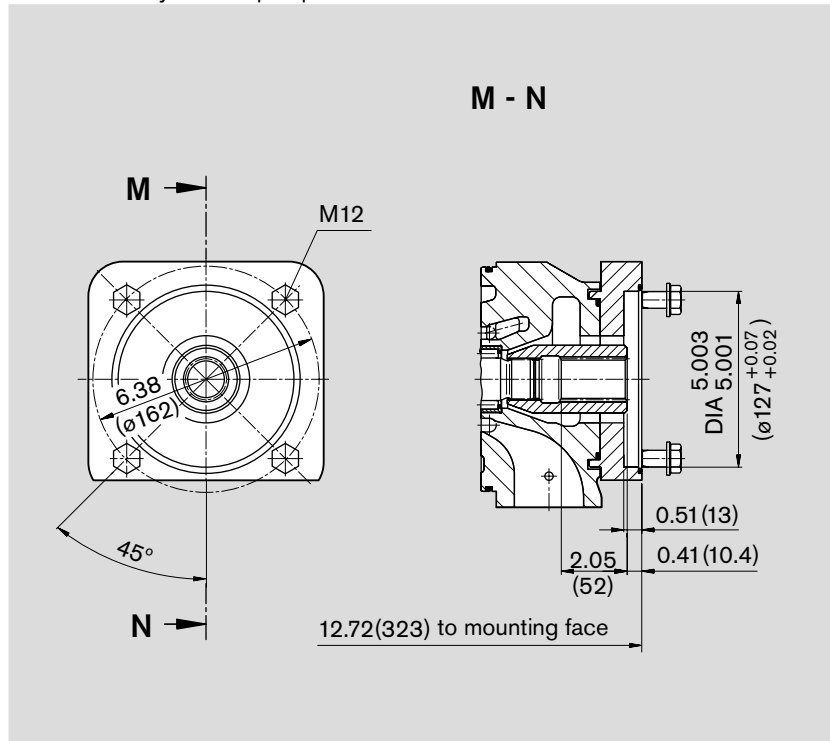

**U16** Flange 127-4 to ISO 3019-1 (SAE C, 4-bolt)  
 Shaft coupler 38-4 to ISO 3019-1 (SAE C-C, 1 1/2 in, 12/24 DP; 17T)<sup>3)</sup>  
 for mounting an AA4VSO/G 71 splined shaft

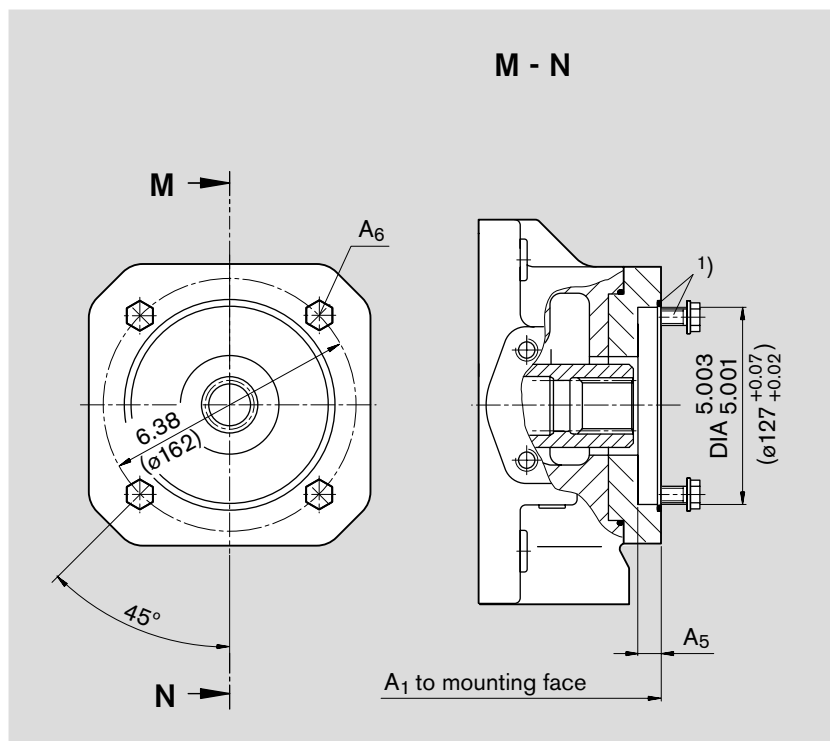

Size	A <sub>1</sub>	A <sub>5</sub>	A <sub>6</sub> <sup>2)</sup>
125	14.61 (371)	0.51 (13)	M12
180	15.55 (395)	0.51 (13)	M12
250	17.91 (455)	0.51 (13)	M12
355	19.06 (484)	0.51 (13)	M12

Further dimensions on request

<sup>1)</sup> Mounting screws and O-ring seal are included with supply

<sup>2)</sup> Thread to DIN 13, for the max. tightening torques observe the general information on page 64

<sup>3)</sup> To ANSI B92.1a-1976, 30° pressure angle, flat base, flank centering, fit class 5

# Dimensions through drives

Before finalising your design please request a certified installation drawing. Dimensions in inches (mm).

**U17** Flange 152-4 to ISO 3019-1 (SAE D, 4-bolt)  
 Shaft coupler 44-4 to ISO 3019-1 (SAE D, 1 3/4 in, 8/16 DP; 13 T)<sup>3)</sup>

for mounting an AA4VSO/G 125 splined shaft, A10VO140/31(2) or AA10VSO 140/31(2) splined shaft S  
 (see RA 92701, RA 92711 or RA 92714)

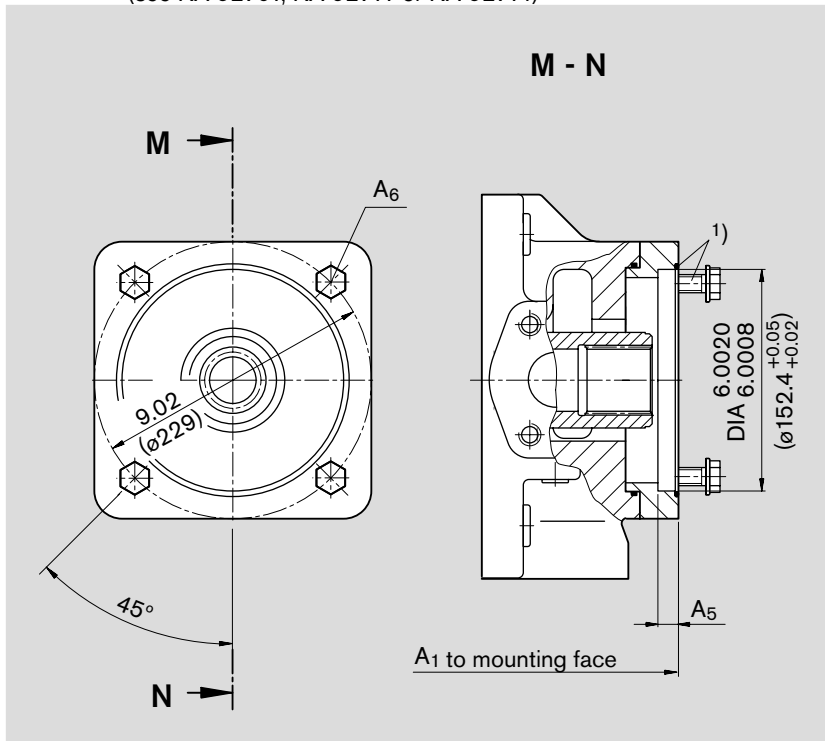

Size	A <sub>1</sub>	A <sub>5</sub>	A <sub>6</sub> <sup>2)</sup>
125	15.12(384)	0.51(13)	M16
180	16.06(408)	0.51(13)	M16
250	17.91(455)	0.51(13)	M16
355	19.06(484)	0.51(13)	M16

Further dimensions on request

**U78** Flange 152-4 to ISO 3019-1 (SAE D, 4-bolt)  
 Shaft coupler 50-4 to ISO 3019-1 (SAE F, 2 in, 8/16 DP; 15 T)<sup>3)</sup>

for mounting an AA4VSO/G 180 splined shaft

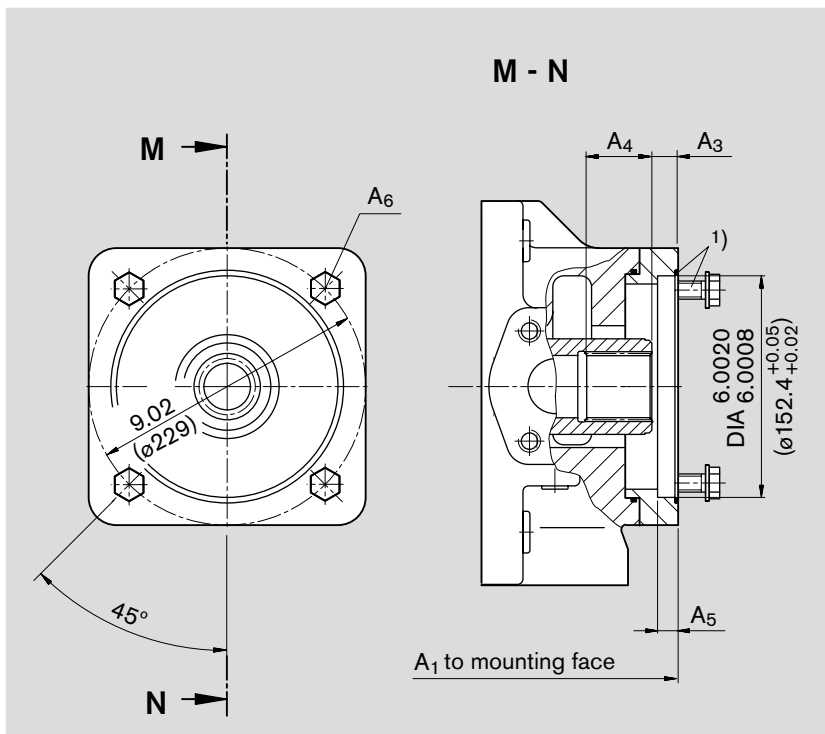

Size	A <sub>1</sub>	A <sub>3</sub>	A <sub>4</sub>
180	17.05(433)	0.41(10.4)	3.39(86.1)
250	18.94(481)	1.20(30.4)	2.33(59.1)
355	20.08(510)	1.20(30.4)	2.33(59.1)

Size	A <sub>5</sub>	A <sub>6</sub> <sup>2)</sup>
180	0.51(13)	M16
250	0.51(13)	M16
355	0.51(13)	M16

<sup>1)</sup> Mounting screws and O-ring seal are included with supply

<sup>2)</sup> Thread to DIN 13, for the max. tightening torques observe the general information on page 64

<sup>3)</sup> To ANSI B92.1a-1976, 30° pressure angle, flat base, flank centering, fit class 5

# Dimensions through drives

Before finalising your design please request a certified installation drawing. Dimensions in inches (mm).

**U18** Flange 165-4 to ISO 3019-1 (SAE E, 4-bolt)  
 Shaft coupler 50-4 to ISO 3019-1 (SAE F, 2 in 8/16 DP; 15 T)<sup>3)</sup>  
 for mounting an AA4VSO/G or AA4CSG 250 or 355 splined shaft

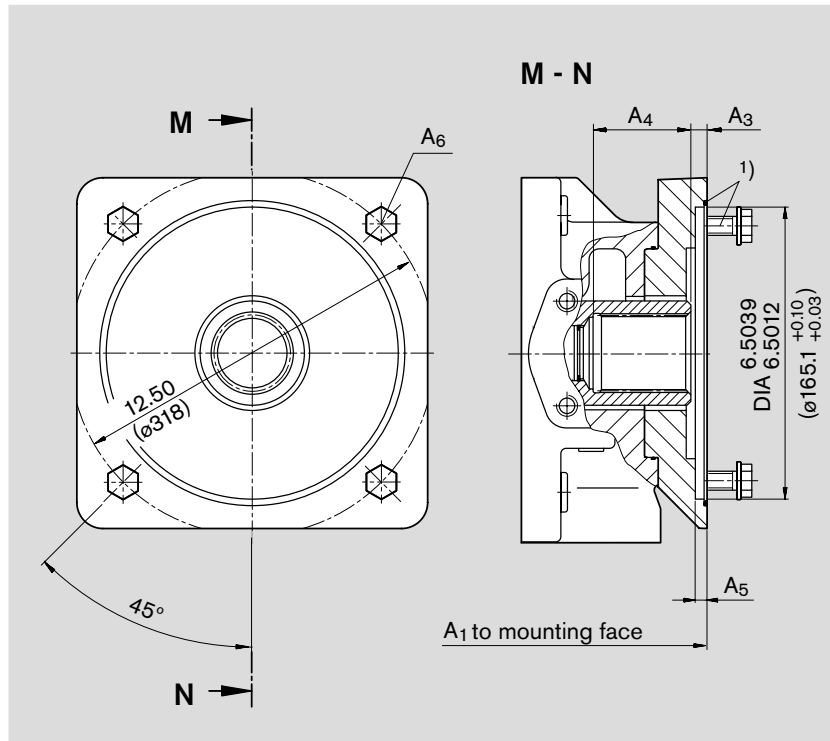

Size	A <sub>1</sub>	A <sub>3</sub>	A <sub>4</sub>
250	18.94(481)	1.20(30.4)	2.33(59.3)
355	20.09(510)	1.20(30.4)	2.34(59.4)

Size	A <sub>5</sub>	A <sub>6</sub> <sup>2)</sup>
250	0.67(17)	M20
355	0.67(17)	M20

<sup>1)</sup> Mounting screws and O-ring seal are included with supply

<sup>2)</sup> Thread to DIN 13, for the max. tightening torques observe the general information on page 64

<sup>3)</sup> To ANSI B92.1a-1976, 30° pressure angle, flat base, flank centering, fit class 5

# Dimensions through drives

Before finalising your design please request a certified installation drawing. Dimensions in inches (mm).

**K31** Flange 125, 4-bolt – 125B4HW to ISO 3019-2  
 Shaft coupler N32x2x14x8H to DIN 5480  
 for mounting an A4VSO/G 40 splined shaft

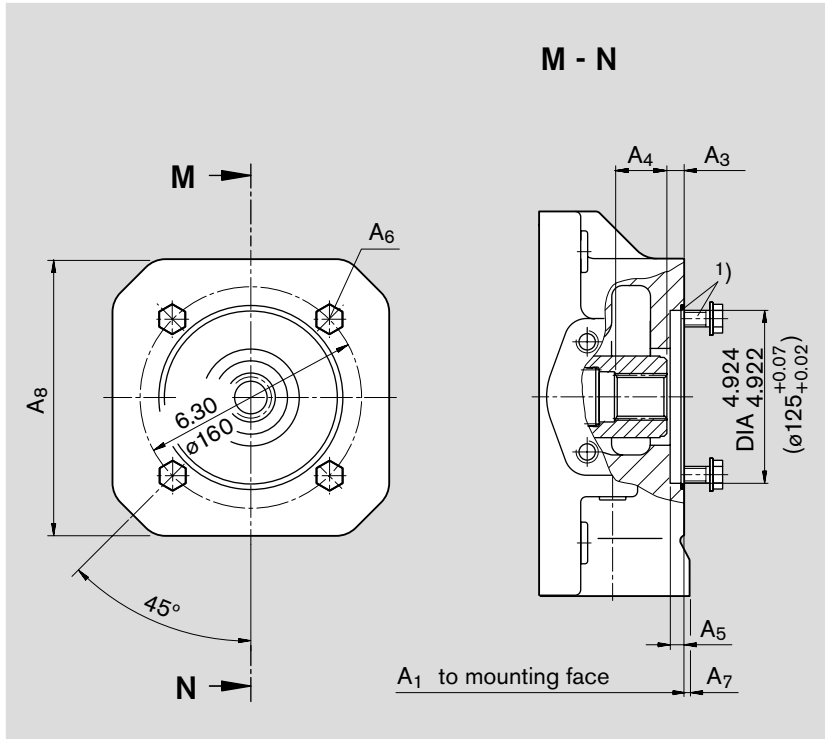

Size	A <sub>1</sub>	A <sub>3</sub>	A <sub>4</sub>
500	19.88(505)	0.49(12.5)	1.52(38.5)
750	in preparation		
1000	in preparation		

Size	A <sub>5</sub>	A <sub>6</sub> <sup>2)</sup>	A <sub>7</sub>
500	0.35(9)	M12	0.59(15)
750	in preparation		
1000	in preparation		

Size	A <sub>8</sub>
500	9.45(240)
750	in preparation
1000	in preparation

**K33** Flange 140, 4-bolt B4HW to ISO 3019-2  
 Shaft coupler N40x2x18x8H to DIN 5480  
 for mounting an A4VSO/G 71 splined shaft

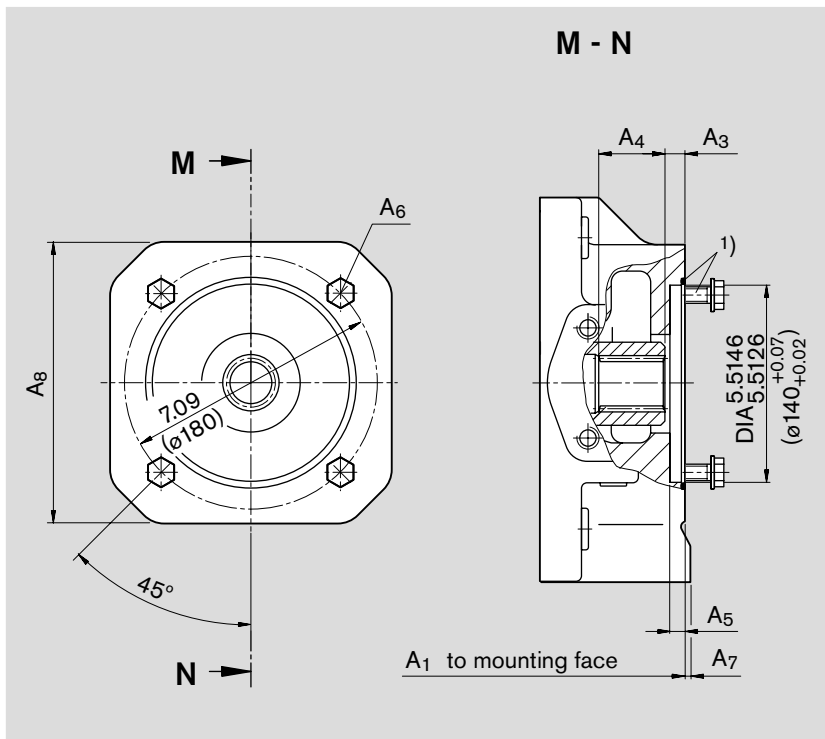

Size	A <sub>1</sub>	A <sub>3</sub>	A <sub>4</sub>
500	19.88(505)	0.49(12.5)	2.24(57)
750	21.85(555)	0.49(12.5)	1.75(44.5)
1000	in preparation		

Size	A <sub>5</sub>	A <sub>6</sub> <sup>2)</sup>	A <sub>7</sub>
500	0.35(9)	M12	0.59(15)
750	0.35(9)	M12	–
1000	in preparation		

Size	A <sub>8</sub>
500	9.45(240)
750	–
1000	in preparation

1) Mounting screws and O-ring seal are included with supply

2) Thread to DIN 13, for the max. tightening torques observe the general information on page 64

# Dimensions through drives

Before finalising your design please request a certified installation drawing. Dimensions in inches (mm).

**K34** Flange 160, 4-bolt – 160B4HW to ISO 3019-2  
 Shaft coupler N50x2x24x8H to DIN 5480  
 for mounting an A4VSO/G 125 or 180 splined shaft

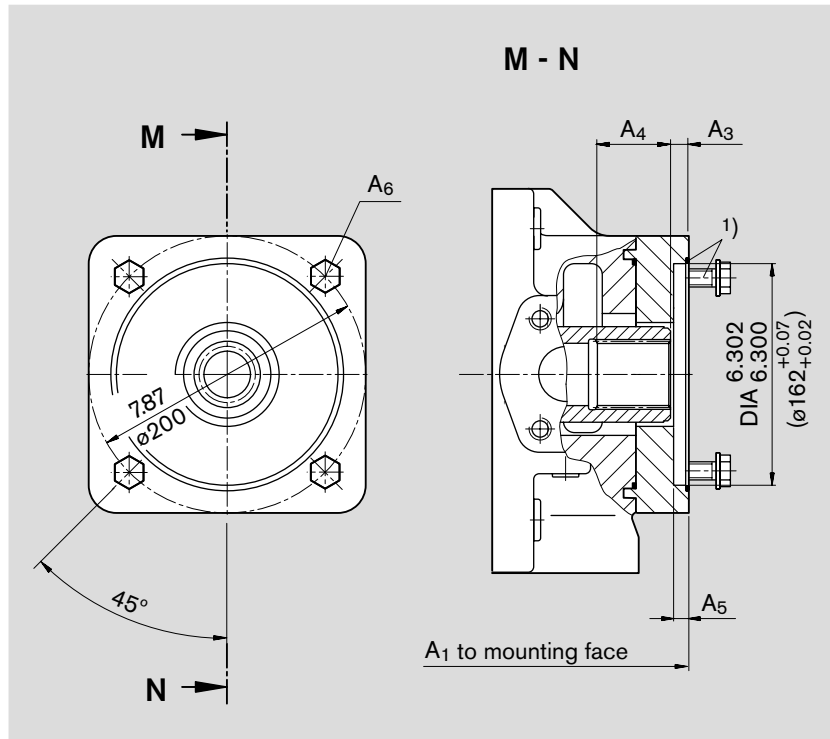

Size	A <sub>1</sub>	A <sub>3</sub>	A <sub>4</sub>
500	19.69(505)	0.53(13.5)	2.15(54.5)
750	21.85(555)	0.49(12.5)	2.19(55.5)
750 *	in preparation		
1000	in preparation		

Size	A <sub>5</sub>	A <sub>6</sub> <sup>2)</sup>
500	0.35(9)	M16
750	0.35(9)	M16
750 *	in preparation	
1000	in preparation	

\* with boost pump

**K35** Flange 224, 4-bolt – 224B4HW to ISO 3019-2  
 Shaft coupler N60x2x28x8H to DIN 5480  
 for mounting an A4VSO/G or A4CSG 250 splined shaft

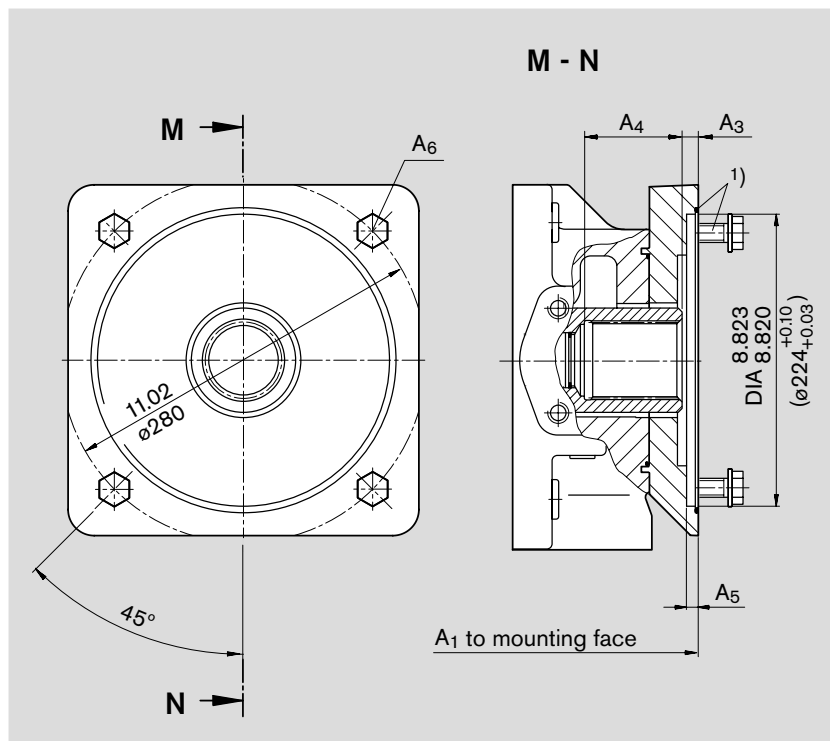

Size	A <sub>1</sub>	A <sub>3</sub>	A <sub>4</sub>
500	21.30(541)	0.49(12.5)	2.91(74)
750	23.27(591)	0.49(12.5)	2.91(74)
750*	in preparation		
1000	in preparation		

Size	A <sub>5</sub>	A <sub>6</sub> <sup>2)</sup>
500	0.35(9)	M20
750	0.35(9)	M20
750*	in preparation	
1000	in preparation	

\* with boost pump

1) Mounting screws and O-ring seal are included with supply

2) Thread to DIN 13, for the max. tightening torques observe the general information on page 64



# Dimensions through drives

Before finalising your design please request a certified installation drawing. Dimensions in inches (mm).

**K77** Flange 224, 4-bolt – 224B4HW to ISO 3019-2  
 Shaft coupler N70x3x22x8H to DIN 5480  
 for mounting an A4VSO/G or A4CSG 355 splined shaft

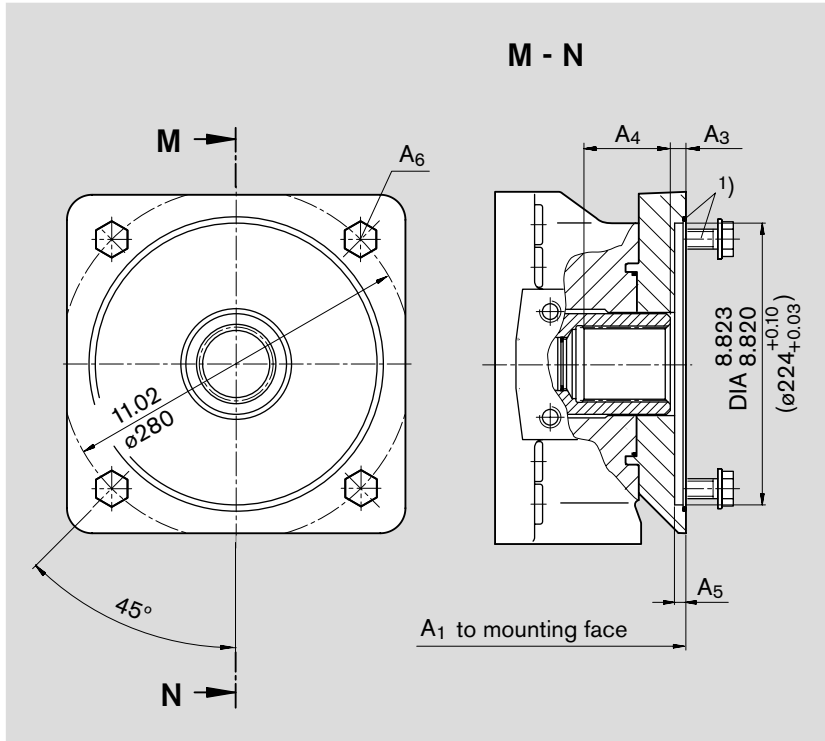

Size	A <sub>1</sub>	A <sub>3</sub>	A <sub>4</sub>
500	21.30(541)	0.49(12.5)	2.99(76)
750	in preparation		
1000	in preparation		

Size	A <sub>5</sub>	A <sub>6</sub> <sup>2)</sup>
500	0.35(9)	M20
750	in preparation	
1000	in preparation	

**K43** Flange 315, 8-bolt – 315D8HW to ISO 3019-2  
 Shaft coupler N80x3x25x8H to DIN 5480  
 for mounting an A4VSO/G or A4CSG 500 splined shaft

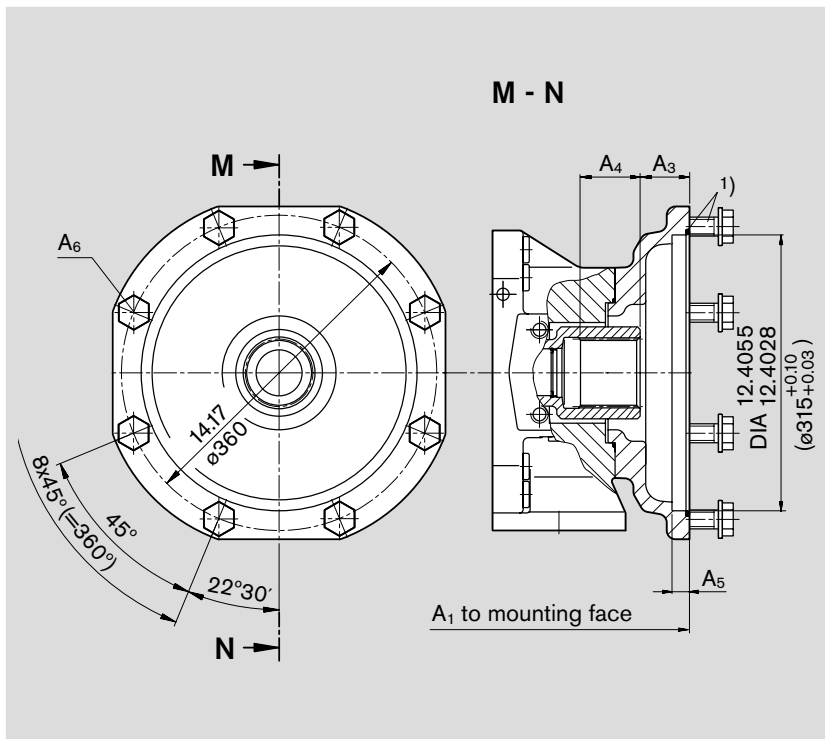

Size	A <sub>1</sub>	A <sub>3</sub>	A <sub>4</sub>
500	23.23(590)	2.11(53.5)	2.83(71.9)
750	25.20(640)	2.11(53.5)	2.83(71.9)
750*	in preparation		
1000	in preparation		

Size	A <sub>5</sub>	A <sub>6</sub> <sup>2)</sup>
500	0.75(19)	M20
750	0.75(19)	M20
750*	in preparation	
1000	in preparation	

\* with boost pump

1) Mounting screws and O-ring seal are included with supply  
 2) Thread to DIN 13, for the max. tightening torques observe the general information on page 64

# Dimensions through drives

Before finalising your design please request a certified installation drawing. Dimensions in inches (mm).

**K76** Flange 400, 8-bolt – 400D8HW to ISO 3019-2  
 Shaft coupler N90x3x28x8H to DIN 5480  
 for mounting an A4VSO/G or A4CSG 750 splined shaft

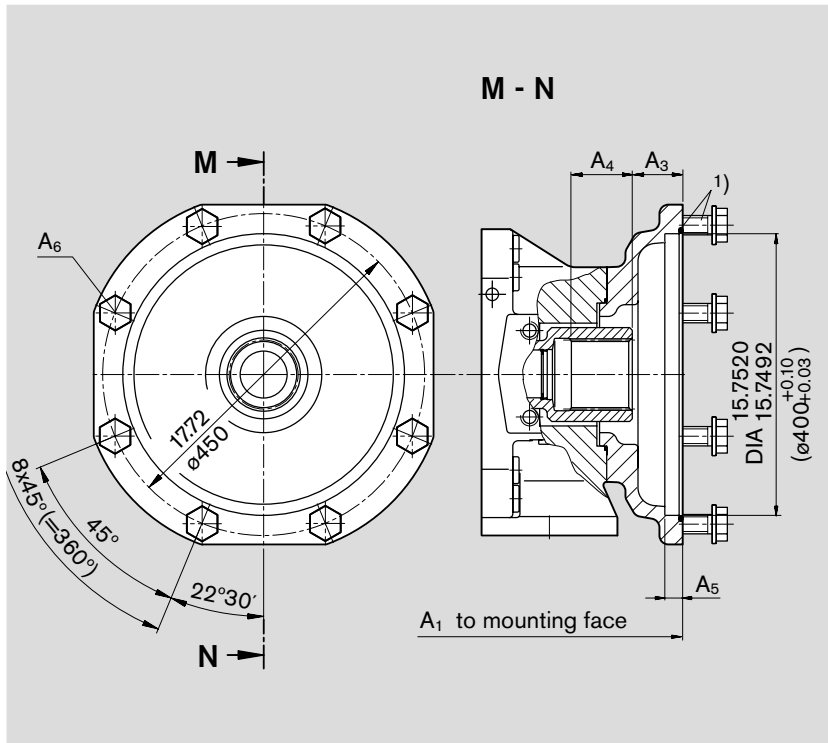

Size	A <sub>1</sub>	A <sub>3</sub>	A <sub>4</sub>
750	25.79(655)	2.09(53)	4.09(104)
750*	in preparation		
1000	in preparation		

Size	A <sub>5</sub>	A <sub>6</sub> <sup>2)</sup>
750	0.75(19)	M20
750*	in preparation	
1000	in preparation	

\* with boost pump

**K88** Flange 400, 8-bolt – 400D8HW to ISO 3019-2  
 Shaft coupler N100x3x32x8H to DIN 5480  
 for mounting an A4VSO/G 1000 splined shaft

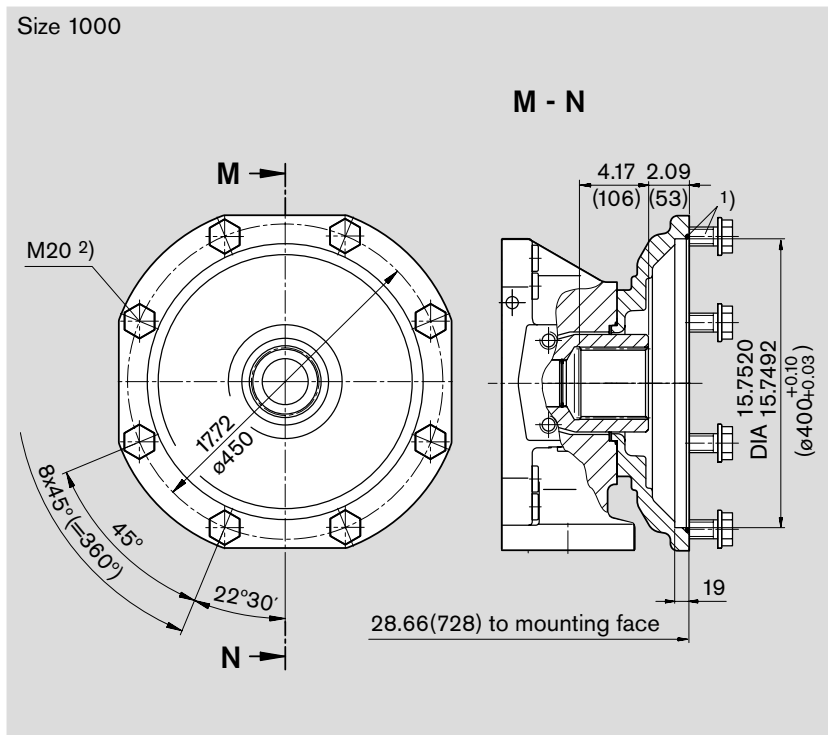

1) Mounting screws and O-ring seal are included with supply

2) Thread to DIN 13, for the max. tightening torques observe the general information on page 64

# Dimensions through drives

Before finalising your design please request a certified installation drawing. Dimensions in inches (mm).

## K01 Flange 82-2 (SAE A) to ISO 3019-1 Shaft coupler for splined shaft, 16-4 SAE A, 5/8 in, 16/32 DP; 9T <sup>3)</sup>

for mounting an external gear pump AZ-PF-1X-004 ... 022 (see RE 10089)  
Rexroth recommends a special execution of the gear pump, please consult us

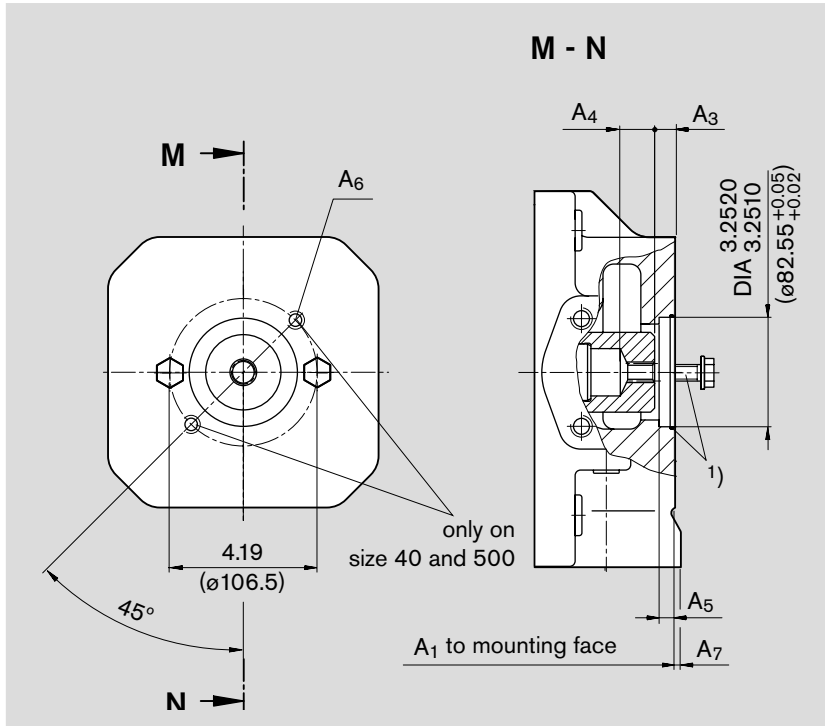

Size	A <sub>1</sub>	A <sub>3</sub>	A <sub>4</sub>
40	10.43(265)	0.41(10.3)	1.02(25.9)
71	11.54(293)	0.41(10.3)	0.97(24.6)
500	19.88(505)	0.41(10.3)	1.29(32.7)
750	21.85(555)	0.41(10.3)	1.29(32.7)
750*	in preparation		
1000	in preparation		

NG	A <sub>5</sub>	A <sub>6</sub> <sup>2)</sup>	A <sub>7</sub>
40	0.39(10)	M10	-
71	0.39(10)	M10	0.08(2)
500	0.39(10)	M10	0.59(15)
750	0.39(10)	M10	-
750*	in preparation		
1000	in preparation		

\* with boost pump

## U01 Flange 82-2 (SAE A) to ISO 3019-1 Shaft coupler for splined shaft, 16-4 SAE A, 5/8 in, 16/32 DP; 9T <sup>3)</sup>

for mounting an external gear pump AZ-PF-1X-004 ... 022 (see RE 10089)  
Rexroth recommends a special execution of the gear pump, please consult us

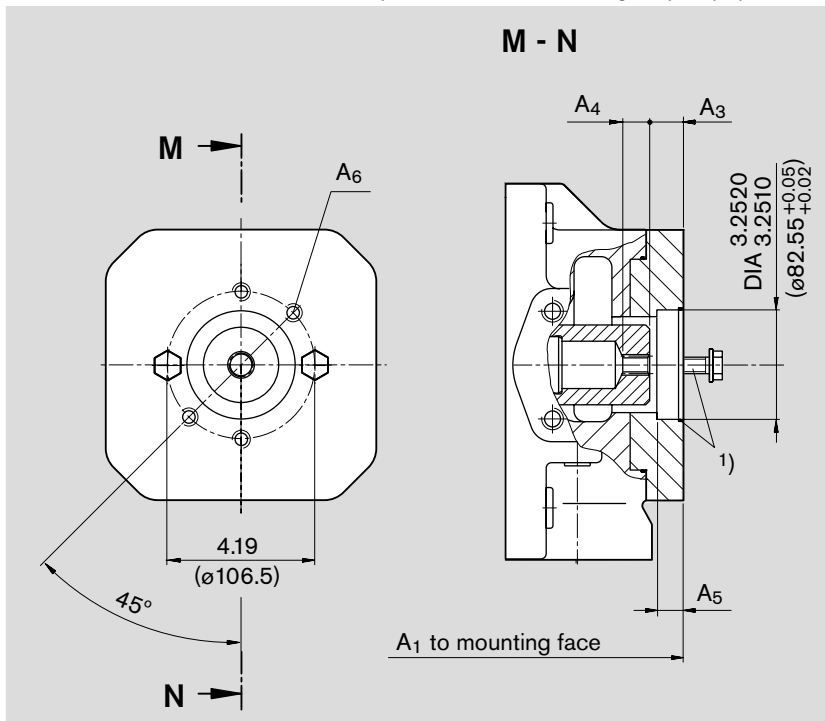

Size	A <sub>1</sub>	A <sub>3</sub>	A <sub>4</sub>
125	14.61(371)	0.63(16)	0.76(19.4)
180	15.55(395)	0.63(16)	0.76(19.4)
250	17.91(455)	0.63(16)	0.76(19.4)
355	19.06(484)	0.63(16)	0.76(19.4)

Size	A <sub>5</sub>	A <sub>6</sub> <sup>2)</sup>
125	0.51(13)	M10
180	0.51(13)	M10
250	0.51(13)	M10
355	0.51(13)	M10

1) 2 mounting screws and O-ring seal are included with supply

2) Thread to DIN 13, for the max. tightening torques observe the general information on page 64

3) To ANSI B92.1a-1976, 30° pressure angle, flat base, flank centering, fit class 5

# Dimensions through drives

Before finalising your design please request a certified installation drawing. Dimensions in inches (mm).

**K52** Flange 82-2 (SAE A) to ISO 3019-1  
**Shaft coupler** for splined shaft, 19-4 SAE A-B, 3/4 in, 16/32 DP; 11T<sup>3)</sup>

for mounting an A10VSO 18/31 splined shaft S (see RA 92711) or A10VSO10 or 18/52 splined shaft S (see RA 92703)

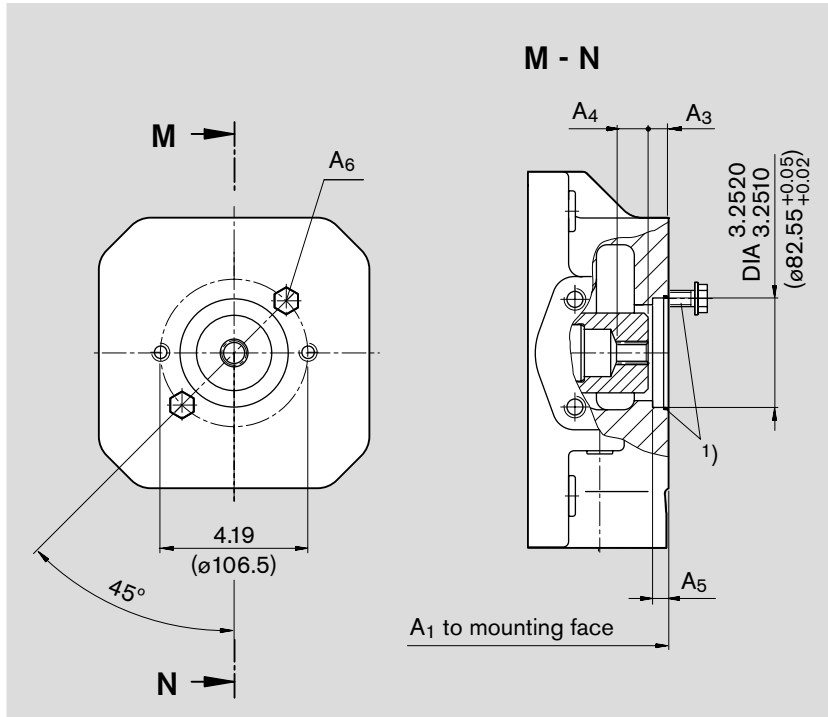

Size	A <sub>1</sub>	A <sub>3</sub>	A <sub>4</sub>
40	10.43(265)	0.41(10.5)	1.33(33.8)
71	12.48(317)	0.41(10.5)	1.18(30)
500	in preparation		
750	in preparation		
1000	in preparation		
NG	A <sub>5</sub>	A <sub>6</sub> <sup>2)</sup>	
40	0.39(10)	M10	
71	0.39(10)	M10	
500	in preparation		
750	in preparation		
1000	in preparation		

**U52** Flange 82-2 (SAE A) to ISO 3019-1  
**Shaft coupler** for splined shaft, 19-4 SAE A-B, 3/4 in, 16/32 DP; 11T<sup>3)</sup>

for mounting an A10VSO 18/31 splined shaft S (see RA 92711) or A10VSO10 or 18/52 splined shaft S (see RA 92703)

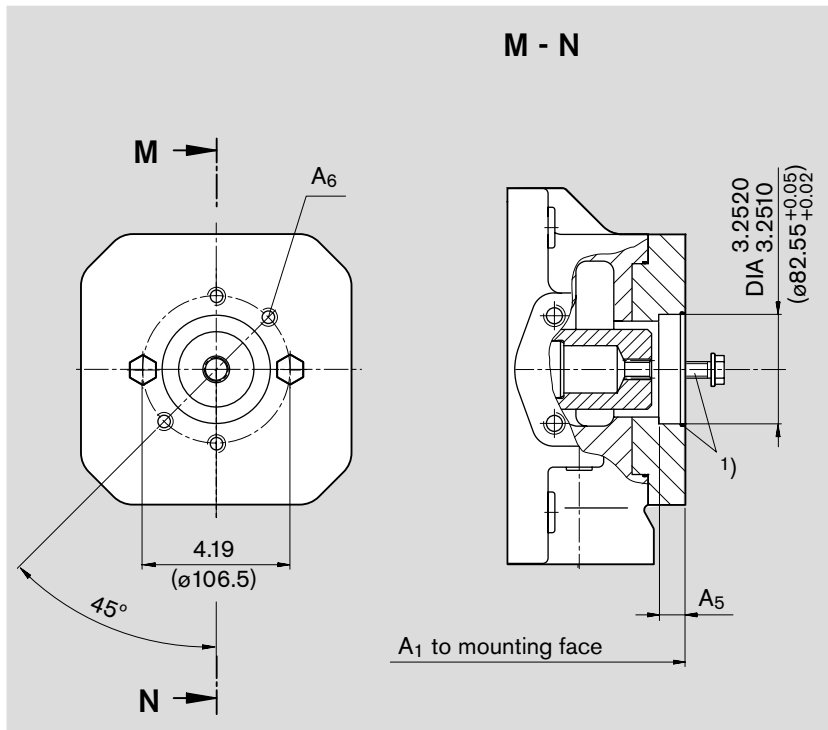

Size	A <sub>1</sub>	A <sub>5</sub>	A <sub>6</sub> <sup>2)</sup>
125	14.61(371)	0.51(13)	M10
180	15.55(395)	0.51(13)	M10
250	17.91(455)	0.51(13)	M10
355	19.06(484)	0.51(13)	M10

Further dimensions on request

1) 2 mounting screws and O-ring seal are included with supply

2) Thread to DIN 13, for the max. tightening torques observe the general information on page 64

3) To ANSI B92.1a-1976, 30° pressure angle, flat base, flank centering, fit class 5

# Dimensions through drives

Before finalising your design please request a certified installation drawing. Dimensions in inches (mm).

## K68 Flange 101-2 (SAE B) to ISO 3019-1 Shaft coupler for splined shaft 22-4 SAE B, 7/8 in, 16/32 DP; 13T<sup>3)</sup>

for mounting an external gear pump AZ-PN-1X020...032 (see RE 10091 or an A10VO 28/31 and 52(53) or AA10VSO 28/31 splined shaft S (see RA 92701, RA 92703 or RA 92711)  
Rexroth recommends a special excution of the gear pump, please consult us

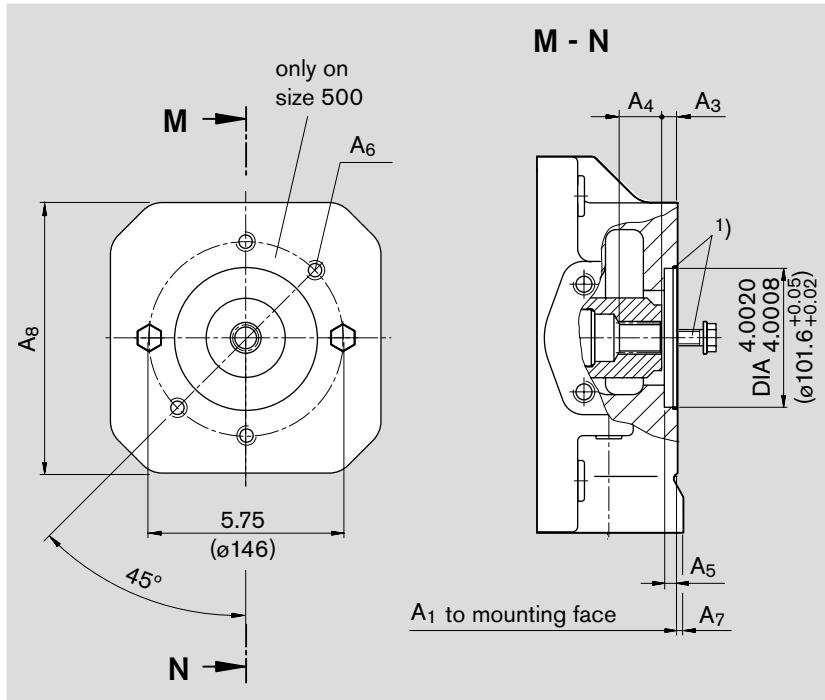

Size	A <sub>1</sub>	A <sub>3</sub>	A <sub>4</sub>
40	11.50(292)	0.80(20.4)	0.91(23.1)
71	12.76(324)	0.41(10.4)	1.38(35.1)
500	19.88(505)	0.77(19.5)	0.98(25)
750	in preparation		
1000	in preparation		

Size	A <sub>5</sub>	A <sub>6</sub> <sup>2)</sup>	A <sub>7</sub>
40	0.39(10)	M12	-
71	0.39(10)	M12	-
500	0.39(10)	M12	0.59(15)
750	in preparation		
1000	in preparation		

Size	A <sub>8</sub>
40	-
71	-
500	9.45(240)
750	in preparation
1000	in preparation

## U68 Flange 101-2 (SAE B) to ISO 3019-1 Shaft coupler for splined shaft 22-4 SAE B, 7/8 in, 16/32 DP; 13T<sup>3)</sup>

for mounting an external gear pump AZ-PN-1X020...032 (see RE 10091 or an A10VO 28/31 and 52(53) or AA10VSO 28/31 splined shaft S (see RA 92701, RA 92703 or RA 92711)  
Rexroth recommends a special excution of the gear pump, please consult us

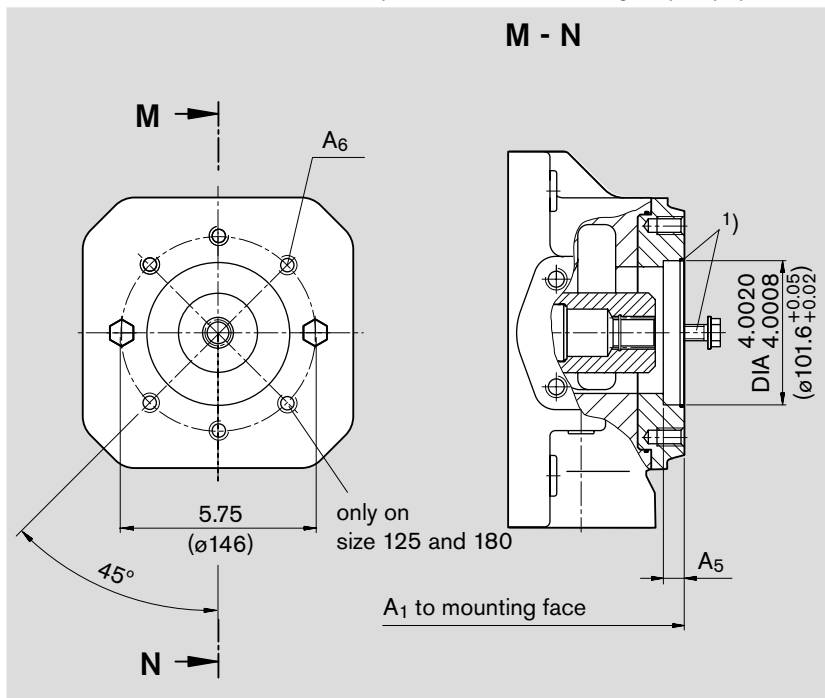

Size	A <sub>1</sub>	A <sub>5</sub>	A <sub>6</sub> <sup>2)</sup>
125	14.61(371)	0.51(13)	M12
180	15.55(395)	0.51(13)	M12
250	17.91(455)	0.51(13)	M12
355	19.06(484)	0.51(13)	M12

Further dimensions on request

1) 2 mounting screws and O-ring seal are included with supply

2) Thread to DIN 13, for the max. tightening torques observe the general information on page 64

3) To ANSI B92.1a-1976, 30° pressure angle, flat base, flank centering, fit class 5

# Dimensions through drives

Before finalising your design please request a certified installation drawing. Dimensions in inches (mm).

**K04 Flange 101-2 (SAE B) to ISO 3019-1**  
**Shaft coupler** for splined shaft 25-4 SAE B-B, 1 in, 16/32 DP; 15T<sup>3)</sup>  
 for mounting an A10VO 45/31 and 52 (53) or AA10VSO 45/31 splined shaft S (see RA 92701, RA 92703 or RA 92711)  
 or an internal gear pump PGH4 (see RE 10223)

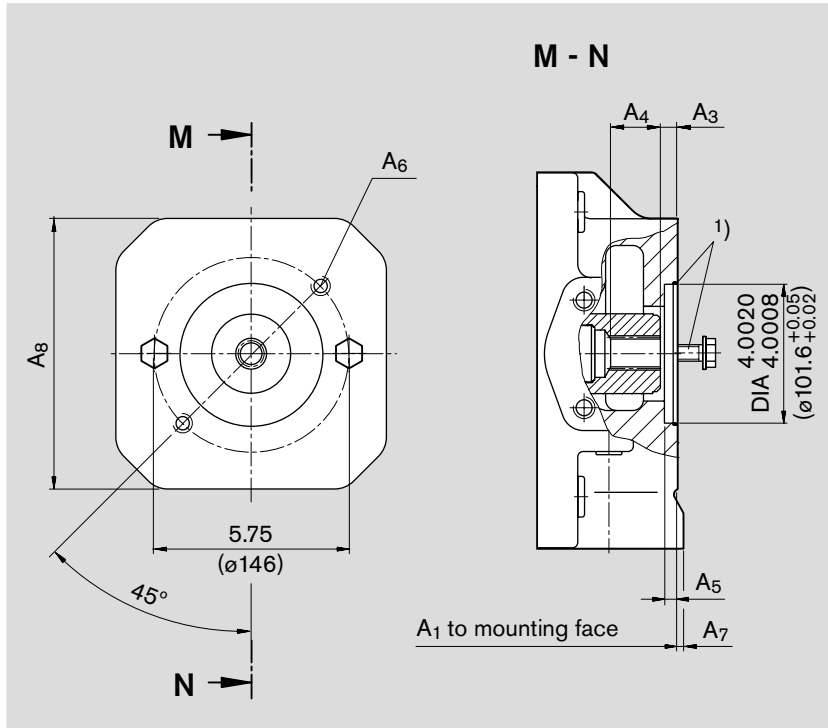

Size	A <sub>1</sub>	A <sub>3</sub>	A <sub>4</sub>
40	11.50(292)	0.41(10.4)	1.49(37.9)
71	12.76(324)	0.41(10.3)	1.41(35.7)
500	19.88(505)	0.41(10.3)	1.14(28.9)
750	in preparation		
1000	in preparation		

Size	A <sub>5</sub>	A <sub>6</sub> <sup>2)</sup>	A <sub>7</sub>
40	0.39(10)	M12	-
71	0.39(10)	M12	-
500	0.39(10)	M12	0.59(15)
750	in preparation		
1000	in preparation		

Size	A <sub>8</sub>
40	-
71	-
500	9.45(240)
750	in preparation
1000	in preparation

**U04 Flange 101-2 (SAE B) to ISO 3019-1**  
**Shaft coupler** for splined shaft 25-4 SAE B-B, 1 in, 16/32 DP; 15T<sup>3)</sup>  
 for mounting an A10VO 45/31 and 52 (53) or AA10VSO 45/31 splined shaft S (see RA 92701, RA 92703 or RA 92711)  
 or an internal gear pump PGH4 (see RE 10223)

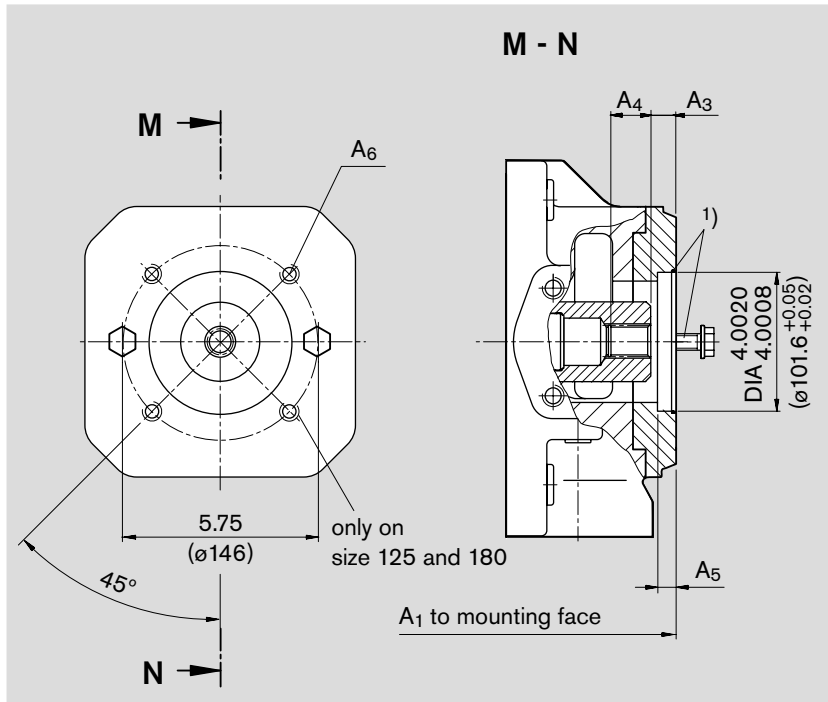

Size	A <sub>1</sub>	A <sub>3</sub>	A <sub>4</sub>
125	14.53(371)	0.74(18.9)	1.16(29.4)
180	15.55(395)	0.74(18.9)	1.16(29.4)
250	17.91(455)	0.74(18.9)	1.16(29.4)
355	19.06(484)	0.74(18.9)	1.16(29.4)

Size	A <sub>5</sub>	A <sub>6</sub> <sup>2)</sup>
125	0.51(13)	M12
180	0.51(13)	M12
250	0.51(13)	M12
355	0.51(13)	M12

1) 2 mounting screws and O-ring seal are included with supply  
 2) Thread to DIN 13, for the max. tightening torques observe the general information on page 64  
 3) To ANSI B92.1a-1976, 30° pressure angle, flat base, flank centering, fit class 5

# Dimensions through drives

Before finalising your design please request a certified installation drawing. Dimensions in inches (mm).

**K07** Flange 127-2 (SAE C) to ISO 3019-1  
**Shaft coupler** for splined shaft 32-4 SAE C, 1 1/4 in, 12/24 DP; 14T<sup>3)</sup>  
 for mounting an A10VO 71/31 or AA10VSO 71/31 splined shaft S (see RA 92701 or RA 92711)

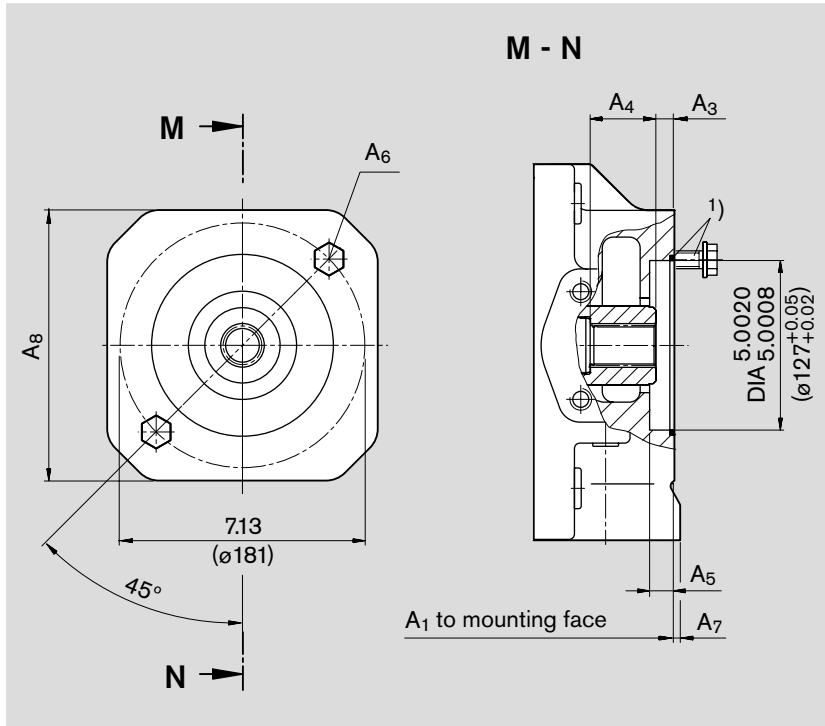

Size	A <sub>1</sub>	A <sub>3</sub>	A <sub>4</sub>
71	12.72(323)	0.41(10.4)	1.87(47.6)
500	19.88(505)	0.44(11.3)	1.58(40.2)
750	in preparation		
1000	in preparation		

Size	A <sub>5</sub>	A <sub>6</sub> <sup>2)</sup>	A <sub>7</sub>
71	0.51(13)	M16	-
500	0.51(13)	M16	0.59(15)
750	in preparation		
1000	in preparation		

Size	A <sub>8</sub>
71	-
500	9.45(240)
750	in preparation
1000	in preparation

**U07** Flange 127-2 (SAE C) to ISO 3019-1  
**Shaft coupler** for splined shaft 32-4 SAE C, 1 1/4 in, 12/24 DP; 14T<sup>3)</sup>  
 for mounting an A10VO 71/31 or AA10VSO 71/31 splined shaft S (see RA 92701 or RA 92711)

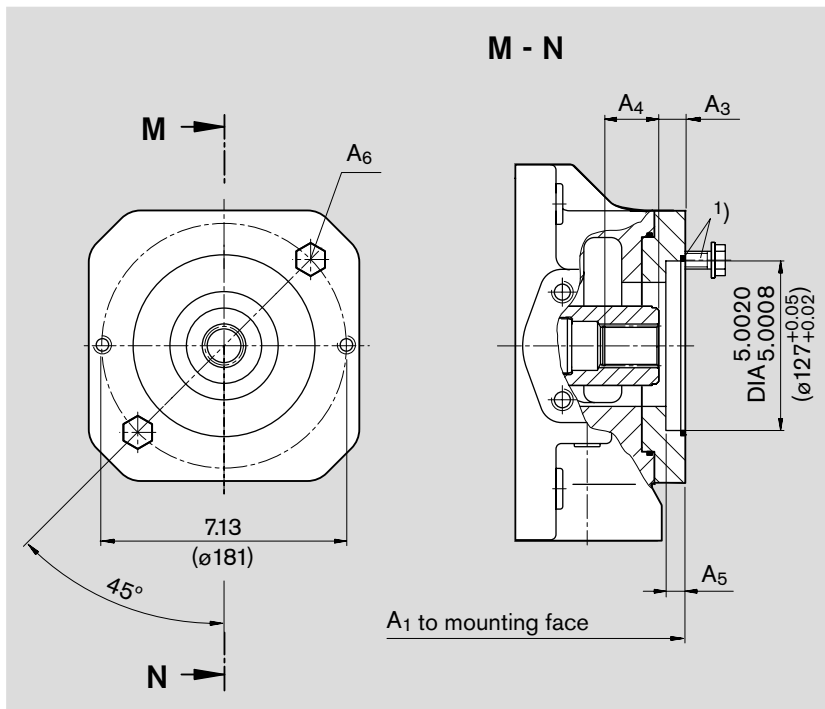

Size	A <sub>1</sub>	A <sub>3</sub>	A <sub>4</sub>
125	14.53(371)	0.82(20.9)	1.49(37.9)
180	15.55(395)	0.82(20.9)	1.49(37.9)
250	17.91(455)	0.82(20.9)	1.49(37.9)
355	19.06(484)	0.82(20.9)	1.49(37.9)

Size	A <sub>5</sub>	A <sub>6</sub> <sup>2)</sup>
125	0.51(13)	M16
180	0.51(13)	M16
250	0.51(13)	M16
355	0.51(13)	M16

1) 2 mounting screws and O-ring seal are included with supply  
 2) Thread to DIN 13, for the max. tightening torques observe the general information on page 64  
 3) To ANSI B92.1a-1976, 30° pressure angle, flat base, flank centering, fit class 5

## Dimensions through drives

Before finalising your design please request a certified installation drawing. Dimensions in inches (mm).

### K24 Flange 127-2 (SAE C) to ISO 3019-1 Shaft coupler for splined shaft 38-4 SAE C-C, 1 1/2 in, 12/24 DP; 17T<sup>3)</sup>

for mounting an A10VO 100/31 or AA10VSO 100/31 splined shaft S (see RA 92701 or RA 92711)  
or an A10VO 85/52(53) splined shaft S (see RA 92703) or an internal gear pump PGH5 (see RE 10223)

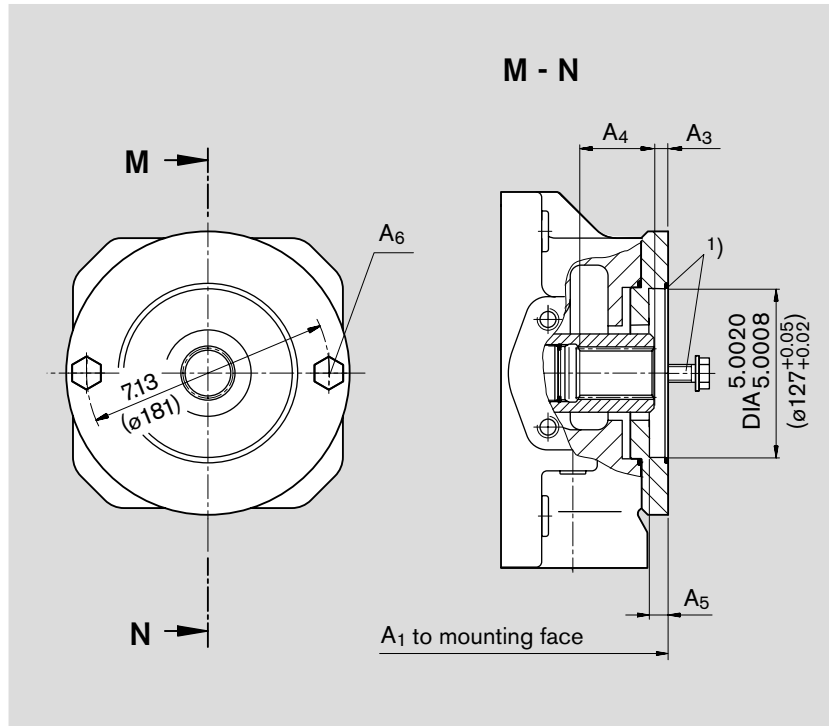

Size	A <sub>1</sub>	A <sub>3</sub>	A <sub>4</sub>
500	19.88(505)	0.41(10.3)	2.23(56.7)
750	in preparation		
1000	in preparation		

Size	A <sub>5</sub>	A <sub>6</sub> <sup>2)</sup>
500	0.51(13)	M16
750	in preparation	
1000	in preparation	

### U24 Flange 127-2 (SAE C) to ISO 3019-1 Shaft coupler for splined shaft 38-4 SAE C-C, 1 1/2 in, 12/24 DP; 17T<sup>3)</sup>

for mounting an A10VO 100/31 or AA10VSO 100/31 splined shaft S (see RA 92701 or RA 92711)  
or an A10VO 85/52(53) splined shaft S (see RA 92703) or an internal gear pump PGH5 (see RE 10223)

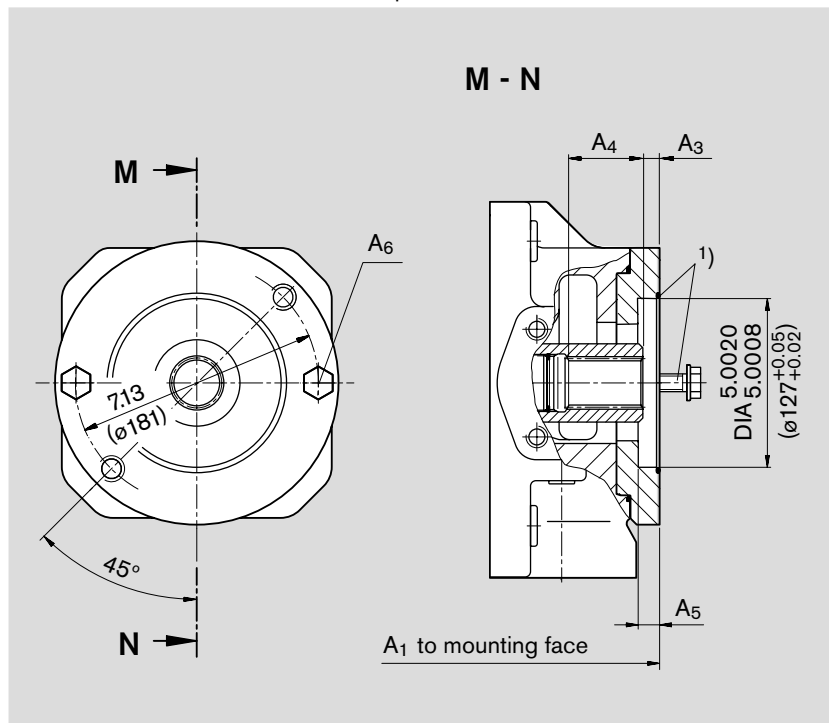

Size	A <sub>1</sub>	A <sub>3</sub>	A <sub>4</sub>
125	14.53(371)	0.41(10.4)	1.97(50)
180	15.55(395)	0.41(10.4)	1.97(50)
250	17.91(455)	0.49(12.4)	2.17(55)
355	19.06(484)	0.49(12.4)	2.17(55)

Size	A <sub>5</sub>	A <sub>6</sub> <sup>2)</sup>
125	0.51(13)	M16
180	0.51(13)	M16
250	0.51(13)	M16
355	0.51(13)	M16

<sup>1)</sup> 2 mounting screws and O-ring seal are included with supply

<sup>2)</sup> Thread to DIN 13, for the max. tightening torques observe the general information on page 64

<sup>3)</sup> To ANSI B92.1a-1976, 30° pressure angle, flat base, flank centering, fit class 5



# Dimensions through drives

Before finalising your design please request a certified installation drawing. Dimensions in inches (mm).

**K17** Flange 152-4 (SAE D) to ISO 3019-1  
**Shaft coupler** for splined shaft 44-4 SAE D, 1 3/4 in, 8/16 DP; 13T<sup>3)</sup>  
 for mounting an A10VO 140/31 or AA10VSO 140/31 splined shaft S (see RA 92701 or RA 92711)

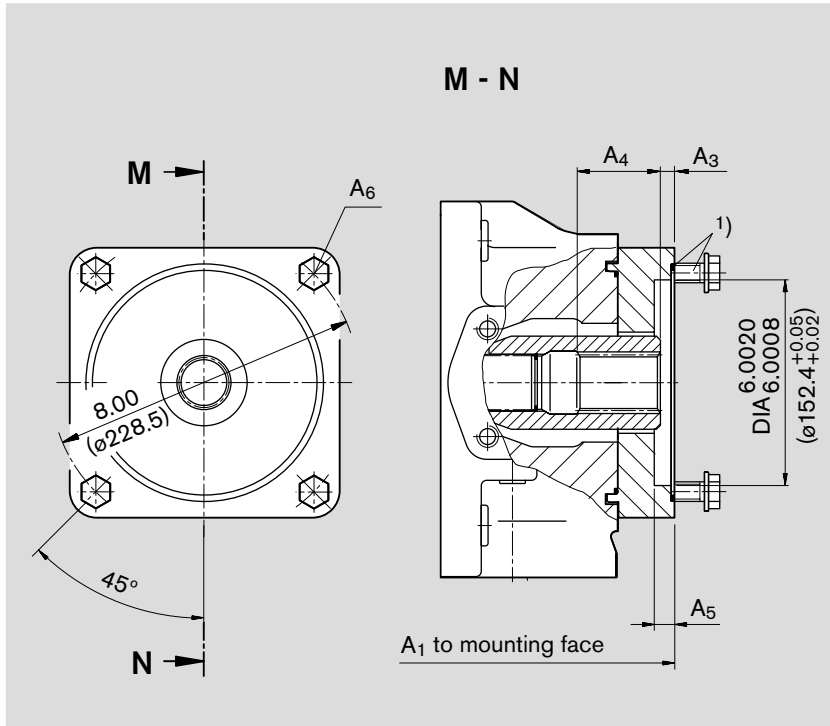

Size	A <sub>1</sub>	A <sub>3</sub>	A <sub>4</sub>
500	19.88(505)	0.41(10.4)	2.35(59.6)
750	in preparation		
1000	in preparation		

Size	A <sub>5</sub>	A <sub>6</sub> <sup>2)</sup>
500	0.51(13)	M16
750	in preparation	
1000	in preparation	

**U17** Flange 152-4 (SAE D) to ISO 3019-1  
**Shaft coupler** for splined shaft 44-4 SAE D, 1 3/4 in, 8/16 DP; 13T<sup>3)</sup>  
 for mounting an A10VO 140/31 or AA10VSO 140/31 splined shaft S (see RA 92701 or RA 92711)

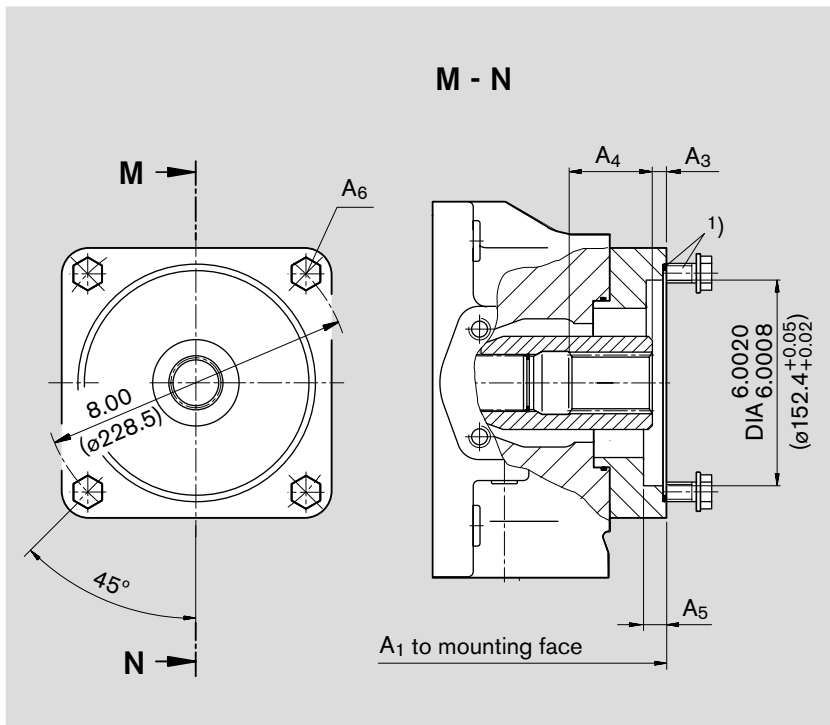

Size	A <sub>1</sub>	A <sub>3</sub>	A <sub>4</sub>
180	16.06(408)	0.41(10.4)	2.44(62)
250	17.91(455)	0.42(10.6)	2.44(62)
355	19.06(484)	0.42(10.6)	2.44(62)

Size	A <sub>5</sub>	A <sub>6</sub> <sup>2)</sup>
180	0.51(13)	M16
250	0.51(13)	M16
355	0.51(13)	M16

1) 2 mounting screws and O-ring seal are included with supply  
 2) Thread to DIN 13, for the max. tightening torques observe the general information on page 64  
 3) To ANSI B92.1a-1976, 30° pressure angle, flat base, flank centering, fit class 5

# Dimensions through drives

Before finalising your design please request a certified installation drawing. Dimensions in inches (mm).

**KB4** Flange 100, 2-bolt – 100A2HW to ISO 3019-2  
**Shaft coupler** for splined shaft, 25-4 SAE B-B, 1 in, 16/32 DP; 15T<sup>3)</sup>  
 for mounting an A10VSO 45/31 splined shaft S – see RE 92711

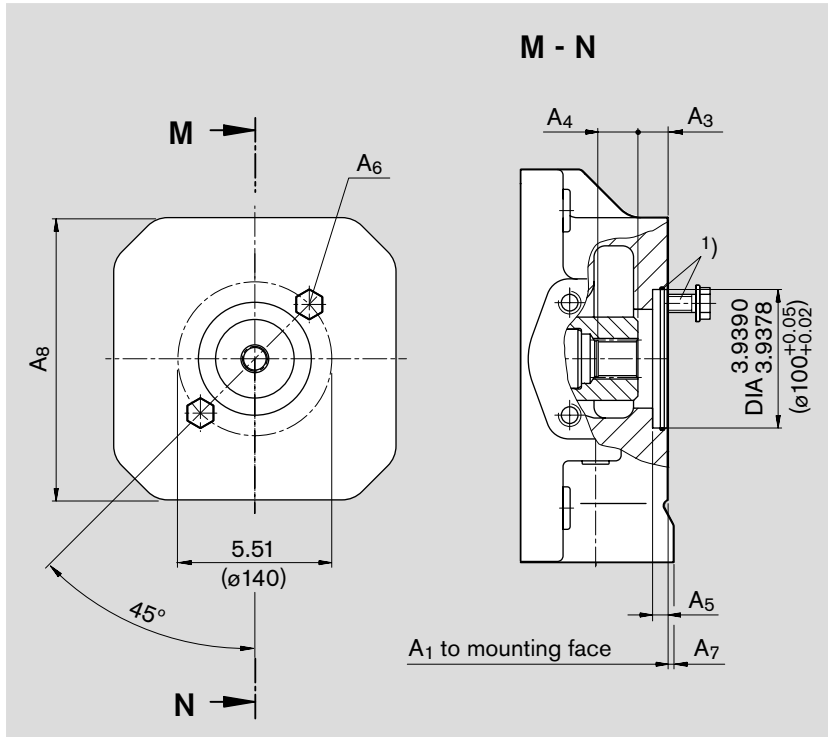

Size	A <sub>1</sub>	A <sub>3</sub>	A <sub>4</sub>
500	19.88(505)	0.80(20.4)	1.14(28.9)
750	in preparation		
1000	in preparation		

  

Size	A <sub>5</sub>	A <sub>6</sub> <sup>2)</sup>	A <sub>7</sub>
500	0.39(10)	M12	0.59(15)
750	in preparation		
1000	in preparation		

Size	A <sub>8</sub>
500	9.45(240)
750	in preparation
1000	in preparation

**KB7** Flange 180, 4-bolt – 180B4HW to ISO 3019-2  
**Shaft coupler** for splined shaft, 44-4 SAE D, 1 3/4 in, 8/16 DP; 13T<sup>3)</sup>  
 for mounting an A10VSO 140/31(32) splined shaft S – see RE 92711 (RE 92714)

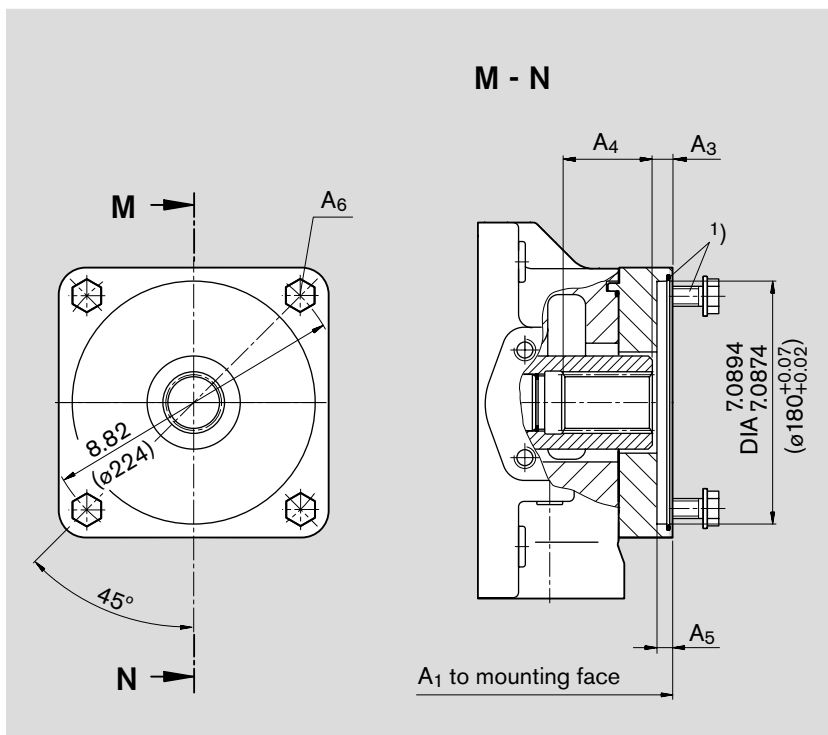

Size	A <sub>1</sub>	A <sub>3</sub>	A <sub>4</sub>
500	20.87(530)	0.41(10.4)	2.50(63.6)
750	in preparation		
1000	in preparation		

Size	A <sub>5</sub>	A <sub>6</sub> <sup>2)</sup>
500	0.39(10)	M16
750	in preparation	
1000	in preparation	

1) 2 mounting screws and O-ring seal are included with supply  
 2) Thread to DIN 13, for the max. tightening torques observe the general information on page 64  
 3) To ANSI B92.1a-1976, 30° pressure angle, flat base, flank centering, fit class 5

# Dimensions through drives

Before finalising your design please request a certified installation drawing. Dimensions in inches (mm).

**K57**     **dia. 63 metric, 4-bolt**  
**Shaft coupler** for keyed shaft dia. 25  
 for mounting a radial piston pump R4 (see RE 11263)

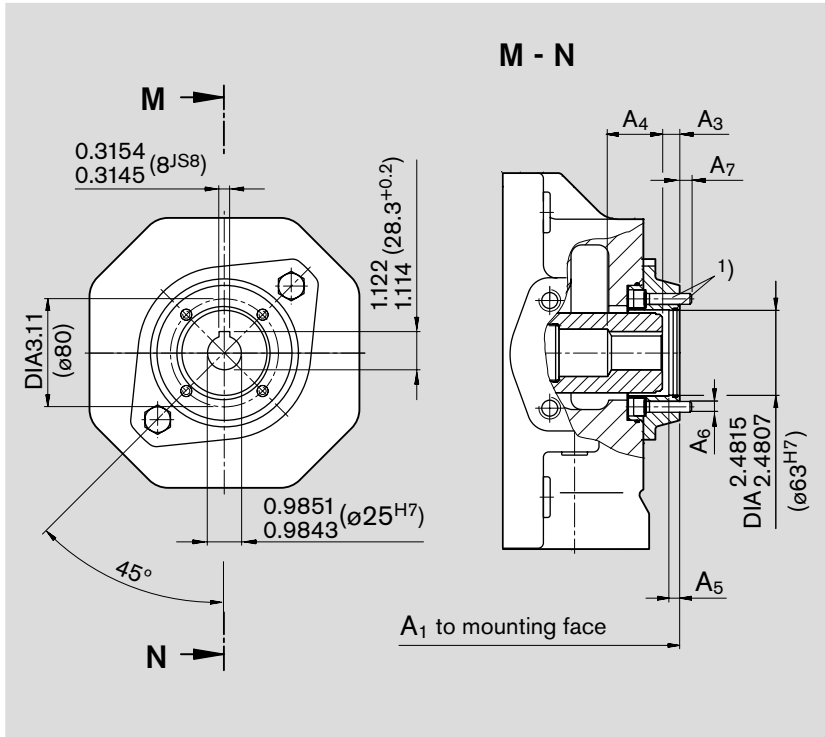

Size	A <sub>1</sub>	A <sub>3</sub>	A <sub>4</sub>
40	11.42(290)	0.43(11)	2.20(56)
71	12.64(321)	0.43(10.9)	1.65(42)
500	in preparation		
750	in preparation		

Size	A <sub>5</sub>	A <sub>6</sub> <sup>2)</sup>	A <sub>7</sub>
40	0.31(8)	M8	0.35(9)
71	0.31(8)	M8	0.35(9)
500	in preparation		
750	in preparation		

Sizes 125...355 with U-through drive in preparation

1) Mounting screws and O-ring seal are included with supply

2) Thread to DIN 13, for the max. tightening torques observe the general information on page 64

# Dimensions through drives

Before finalising your design please request a certified installation drawing. Dimensions in inches (mm).

## K99 Sizes 40 and 71

with through drive shaft, without shaft coupler, without adapter flange, closed with pressure tight cover

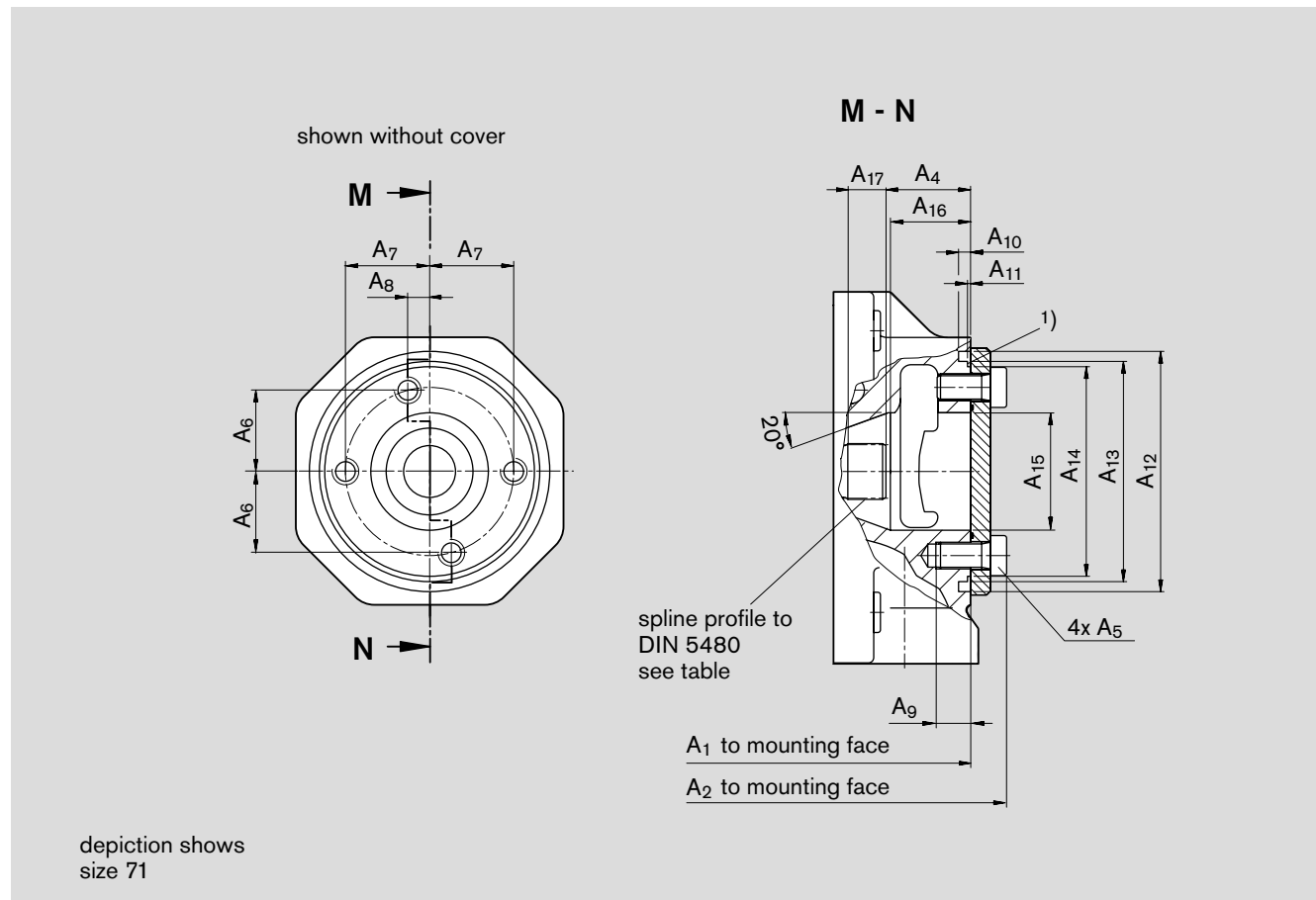

Size Main pump	A <sub>1</sub>	A <sub>2</sub>	A <sub>4</sub>	A <sub>5</sub> <sup>1)</sup>	A <sub>6</sub>	A <sub>7</sub>	A <sub>8</sub>
40	10.43(265)	11.10(282)	2.02(51.3±1)	M12x25	1.46(37±0.2)	1.46(37±0.2)	0
71	11.54(293)	12.28(312)	1.89(48±1)	M12x25	1.67(42.3 ±0.15)	1.77(45 ±0.5)	0.61(15.4±0.15)

Size Main pump	A <sub>9</sub>	A <sub>10</sub>	A <sub>11</sub>	A <sub>12</sub>	A <sub>13</sub>	A <sub>14</sub>
40	0.71(18)	0.35(9)	0.09(2.3 <sup>+0.1</sup> )	Dia4.65(ø118)	Dia 4.1334 4.1325 (ø105 <sub>g6</sub> )	Dia3.843 <sub>-0.016</sub> (ø97.6 <sub>-0.4</sub> )
71	0.71(18)	0.35(9)	0.11(2.7 <sup>+0.1</sup> )	Dia5.12(ø130)	Dia 4.5665 4.5656 (ø116 <sub>g6</sub> )	Dia4.189 <sub>-0.016</sub> (ø106.4 <sub>-0.4</sub> )

Sizes 125...1000 see pages 65 and 66

Size Main pump	A <sub>15</sub>	A <sub>16</sub>	A <sub>17</sub>	Spline profile to DIN 5480	<sup>1)</sup> O-Ring for retrofitting (not in supply)
40	Dia2.05(ø52)	1.73(44)	0.55(14)	W25x1,25x18x9g	99 x 3
71	Dia2.48(ø63)	1.50(38)	0.63(16)	W30x1,25x22x9g	110,72 x 3,53

<sup>1)</sup> Thread to DIN 13, for the max. tightening torques observe the general information on page 64

Sizes 125...1000 see pages 61 and 62

# Dimensions through drives

Before finalising your design please request a certified installation drawing. Dimensions in inches (mm).

## U99 Sizes 125...355

with through drive shaft, without shaft coupler, without adapter flange, closed with pressure tight cover

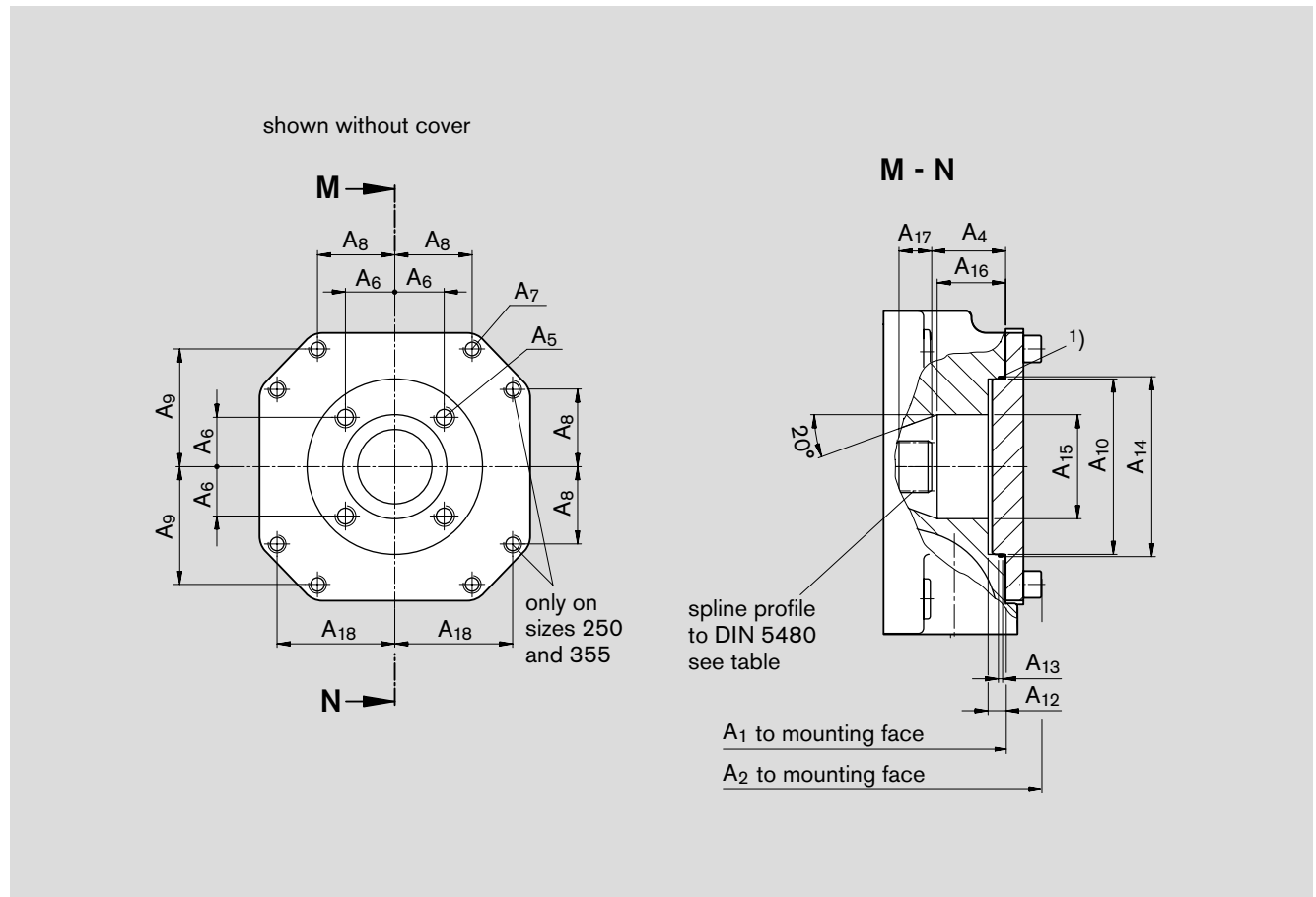

Size Main pump	A <sub>1</sub>	A <sub>2</sub>	A <sub>4</sub>	A <sub>5</sub> <sup>1)</sup>	A <sub>6</sub>	A <sub>7</sub> <sup>1)</sup>	A <sub>8</sub>
125	13.74(349)	14.57(370)	1.957±0.04(49.7±1)	M14; 15 deep	1.31(33.2 <sup>+0.15</sup> )	M12; 18 deep	–
180	14.69(373)	15.51(394)	1.957±0.04(49.7±1)	M14; 15 deep	1.31(33.2 <sup>+0.15</sup> )	M12; 18 deep	–
250	17.05(433)	17.99(457)	2.417±0.04(61.4±1)	M20; 22 deep	1.75(44.5 <sup>+0.15</sup> )	M10; 15 deep	2.29(58.15 <sup>+0.15</sup> )
355	18.19(462)	19.25(489)	2.417±0.04(61.4±1)	M20; 22 deep	1.75(44.5 <sup>+0.15</sup> )	M10; 15 deep	2.29(58.15 <sup>+0.15</sup> )

Size Main pump	A <sub>9</sub>	A <sub>10</sub>	A <sub>12</sub>	A <sub>13</sub>	A <sub>14</sub>	A <sub>15</sub>
125	3.12(79.2 <sup>+0.15</sup> )	Dia 4.6470 4.6457 (ø118 <sup>H7</sup> )	0.35(9)	0.110 <sup>+0.008</sup> (2.8 <sup>+0.2</sup> )	Dia4.76(ø121 <sup>+0.1</sup> )	Dia2.76(ø70)
180	3.12(79.2 <sup>+0.15</sup> )	Dia 4.6470 4.6457 (ø118 <sup>H7</sup> )	0.35(9)	0.110 <sup>+0.008</sup> (2.8 <sup>+0.2</sup> )	Dia4.76(ø121 <sup>+0.1</sup> )	Dia2.76(ø70)
250	3.39(86.2 <sup>+0.15</sup> )	Dia 6.3008 6.2992 (ø160 <sup>H7</sup> )	0.35(9)	0.110 <sup>+0.008</sup> (2.8 <sup>+0.2</sup> )	Dia6.42(ø163 <sup>+0.1</sup> )	Dia3.43(ø87)
355	3.39(86.2 <sup>+0.15</sup> )	Dia 6.3008 6.2992 (ø160 <sup>H7</sup> )	0.35(9)	0.110 <sup>+0.008</sup> (2.8 <sup>+0.2</sup> )	Dia6.42(ø163 <sup>+0.1</sup> )	Dia3.43(ø87)

Size Main pump	A <sub>16</sub>	A <sub>17</sub>	A <sub>18</sub>	Spline profile to DIN 5480	<sup>1)</sup> O-Ring for retrofitting (included in supply)
125	1.81(46)	0.87(22)	–	W35x1.25x26x9g	118 x 2
180	1.81(46)	0.98(25)	–	W35x1.25x26x9g	118 x 2
250	2.53(64)	1.20(30.5)	3.394 <sup>+0.006</sup> (86.2 <sup>+0.15</sup> )	W42x1.25x32x9g	160 x 2
355	2.53(64)	1.34(34)	3.394 <sup>+0.006</sup> (86.2 <sup>+0.15</sup> )	W42x1.25x32x9g	160 x 2

<sup>1)</sup> Thread to DIN 13, for the max. tightening torques observe the general information on page 64  
 Sizes 500...1000 see page 62

# Dimensions through drives

Before finalising your design please request a certified installation drawing. Dimensions in inches (mm).

## K99 Sizes 500...1000

with through drive shaft, without shaft coupler, without adapter flange, closed with pressure tight cover

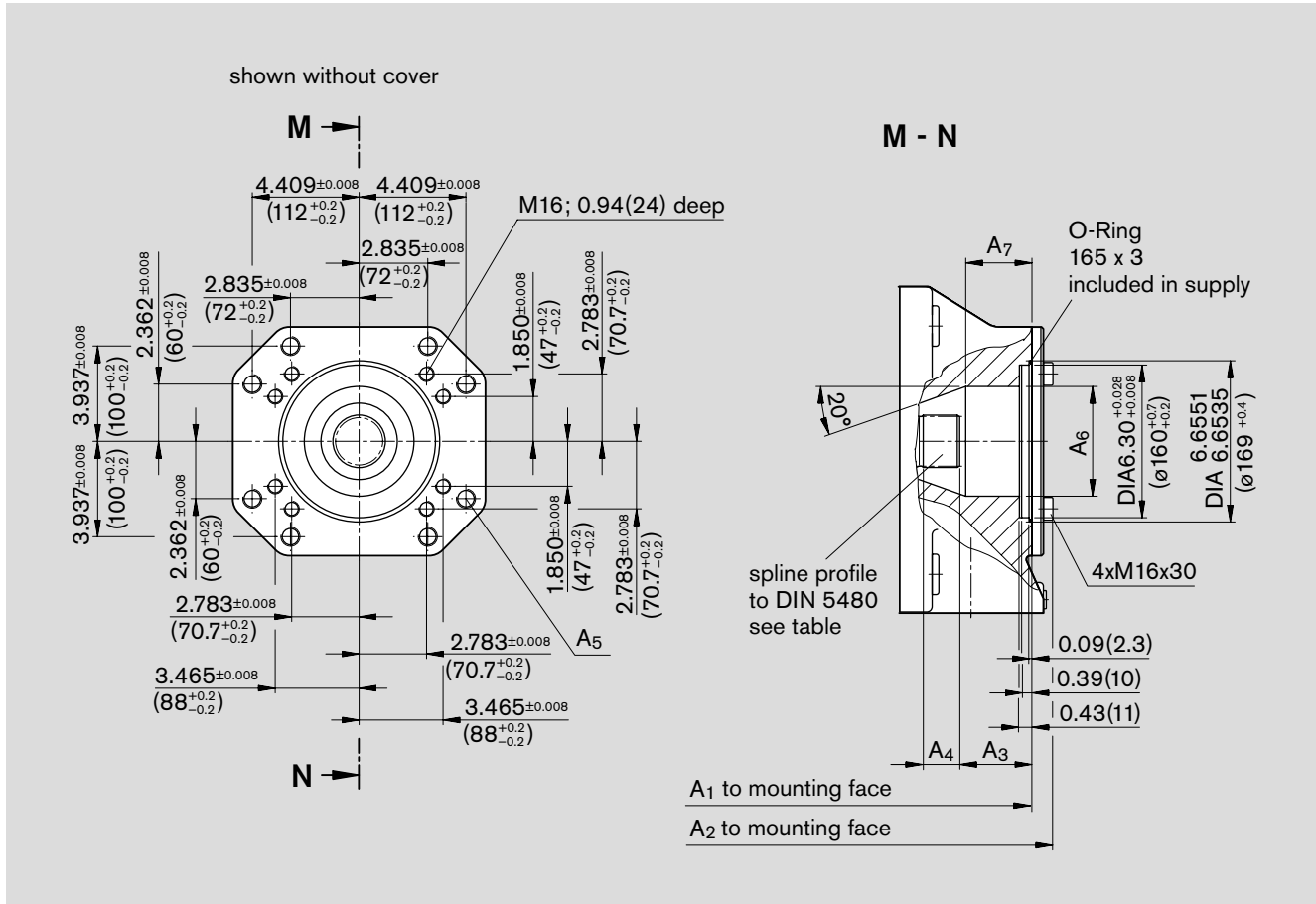

Size Main pump	A <sub>1</sub>	A <sub>2</sub>	A <sub>3</sub>	A <sub>4</sub>	A <sub>5</sub> <sup>1)</sup>	A <sub>6</sub>	A <sub>7</sub>
500	19.88(505)	20.75(527)	2.87(73)	1.61(41)	M20; 0.94(24) deep	Dia4.53(ø115)	2.95(75)
750	21.85(555)	22.72(577)	2.87(73)	1.61(41)	M20; 0.94(24) deep	Dia4.53(ø115)	2.95(75)
750*	in preparation						
1000	24.72(628)	25.59(650)	3.03(77)	2.62(66.5)	M20; 1.18(30) deep	Dia5.43(ø138)	2.56(65)
Size Main pump	Spline profile to DIN 5480						
500	W55x1,25x42x9g						
750	W55x1,25x42x9g						
750*	in preparation						
1000	W65x1,25x50x9g						

\* with boost pump

<sup>1)</sup> Thread to DIN 13, for the max. tightening torques observe the general information on page 64

Sizes 40 and 71 see page 60 and sizes 125...355 see page 61

# Installation notes

## Mounting position:

Optional. The pump case must be filled with fluid during commissioning and remain full when operating.

In order to reduce the operating noise level, all connecting lines (suction, pressure and case drain lines) must be de-coupled from the tank, using flexible elements.

The use of check valves in the case drain line must be avoided. The case drain line must be returned directly to tank without a reduction in cross section.

Exceptions may be possible, please consult us first.

### 1. Vertical installation (shaft end pointing upwards)

With a vertical installation, bearing flushing is recommended to provide lubrication for the front bearing, see page 6.

The following installation conditions must be taken into account:

#### 1.1 Installation into the reservoir

a) When the minimum fluid level is equal to or above the pump mounting flange area: ports »R/L«, »T« and »S« open (see fig. 1).

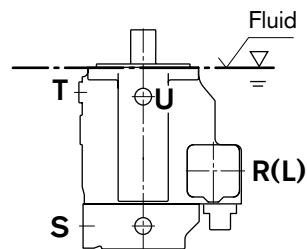

Fig. 1

b) When the minimum fluid level is below the mounting flange area: ports »R/L«, »T« and possibly »S« must be piped as shown in fig. 2. Also observe the conditions as shown in point 1.2.

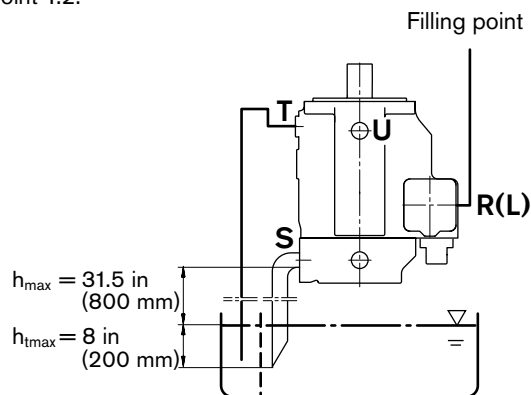

Fig. 2

#### 1.2 Installation outside the reservoir

Before installation, fill the pump housing with the pump in a horizontal position.

Pipe port »T« to tank, »R/L« plugged.

Filling in mounted condition: fill via »R« and bleed via »T«, afterwards plug port »R«.

**Conditions:** A minimum pump inlet pressure (suction pressure) of 12 psi (0,8 bar) abs. is necessary. Avoid mounting above the reservoir in order to reduce the noise level.

### 2. Horizontal installation

The highest situated of the ports »T«, »K<sub>1</sub>«, »K<sub>2</sub>« or »R/L« must be used for filling/bleeding and subsequently to connect the case drain line.

#### 2.1 Installation inside the reservoir

a) When the minimum fluid level is equal to or lies above the upper edge of the pump: case drain port and suction port »S« open (see fig. 3).

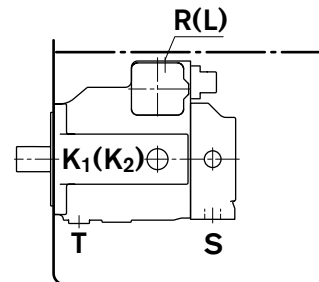

Fig. 3

b) When the minimum fluid level lies below the upper edge of the pump: case drain port and possibly port »S« must be piped, see fig. 4. Observe conditions as shown in point 1.2.

Fill pump housing prior to commissioning.

#### 2.2 Installation outside the reservoir

Fill the pump housing before commissioning.

a) Mounting above the reservoir see fig. 4.

Observe conditions as shown in point 1.2.

b) Mounting below the reservoir

Case drain port and port »S« must be piped (see fig. 5).

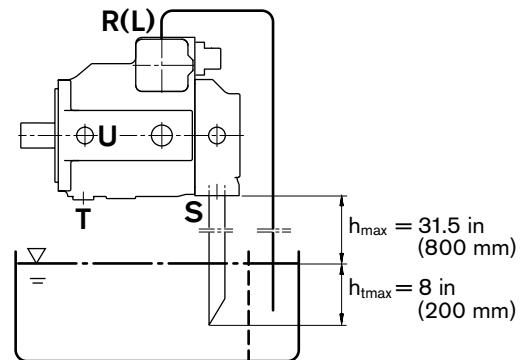

Fig. 4

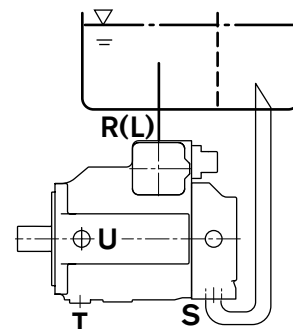

Fig. 5

## General information

- The pump( A)A4VSO was designed for operation in open loop circuits.
- Systems design, installation and commissioning requires trained technicians or tradesmen.
- All hydraulic ports can only be used for the fastening of hydraulic service lines.
- Tightening torques:
  - All tightening torques mentioned in this data sheet are maximum values and may not be exceeded (Maximum values for the female threads in the castings).  
Please comply with the manufacturer's information regarding the max. permissible tightening torques for the used fittings.
  - For fastening screws to ISO 68 / DIN 13 we recommend to check the permissible tightening torque in each individual case acc. to VDI 2230 issue 2003.
- During and shortly after operation of a pump the housing and especially a solenoid can be extremely hot. Take suitable safety measures (e.g. wear protective clothing).
- All given data and information has to be adhered to.

Bosch Rexroth Corporation  
Hydraulics  
Axial & Radial Piston Units  
8 Southchase Court  
Fountain Inn, SC 29644-9018, USA  
Telephone (864) 967-2777  
Facsimile (864) 967-8900  
[www.boschrexroth-us.com](http://www.boschrexroth-us.com)

Bosch Rexroth Corporation  
2315 City Line Road  
Bethlehem, PA 18017-2131, USA  
Telephone (610) 694-8300  
Facsimile (610) 694-8467  
[www.boschrexroth-us.com](http://www.boschrexroth-us.com)

© 2009 Bosch Rexroth Corporation

All rights reserved. Neither this document, nor any part of it, may be reproduced, duplicated, circulated or disseminated, whether by copy, electronic format or any other means, without the prior consent and authorization of Bosch Rexroth Corp.

The data and illustrations in this brochure/data sheet are intended only to describe or depict the products. No representation or warranty, either express or implied, relating to merchantability or fitness for intended use, is given or intended by virtue of the information contained in this brochure/data sheet. The information contained in this brochure/data sheet in no way relieves the user of its obligation to insure the proper use of the products for a specific use or application. All products contained in this brochure/data sheet are subject to normal wear and tear from usage.

Subject to change.