

Hydrostatic Pump Repair

www.hydrostaticpumprepair.net

Phone: 800-361-0028

Email: sales@hydrostatic-transmission.com

Rexroth
Bosch Group

Proportional pressure reducing valve, pilot operated

RE 29279/12.10
Replaces: 01.09

1/14

Types ZDRE; ZDREE

Size 10
Component series 2X
Maximum pressure setting 315 bar
Maximum flow 80 l/min

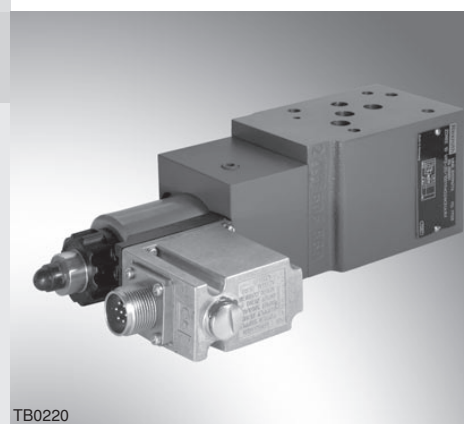

TB0220

Table of contents

Features	1
Ordering code	2
Symbols	3
Function, section	4
Pilot oil supply for directional valve mounted above	5
Technical data	6 and 7
Electrical connection	8 and 9
Integrated electronics (OBE) of type ZDREE	9
Characteristic curves	10 to 12
Unit dimensions	13

Features

1	– Pilot operated valve for reducing a system pressure
2	– Actuation by proportional solenoid, which can be rotated
3	– Sandwich plate design
4	– Porting pattern to DIN 24340-A and ISO 4401
5	– 4 pressure ratings
6 and 7	– Valve and control electronics from a single source
8 and 9	– External control electronics for type ZDRE
9	– Linear command value/pressure characteristic curve
10 to 12	– Integrated electronics (OBE) with type ZDREE, with low manufacturing tolerance of the command value/pressure characteristic curve
13	

Information on available spare parts:
www.boschrexroth.com/spc

Ordering code

Z	DRE		10	VP	2	-2X/		M	G24				*
----------	------------	--	-----------	-----------	----------	-------------	--	----------	------------	--	--	--	----------

Sandwich plate = **Z**

Proportional pressure reducing valve = **DRE**

For external electronics = **No code**

With integrated electronics = **E**

Size 10 = **10**

Pressure reduction in channel P1 = **VP**

Preferred position of mating connector = **2**

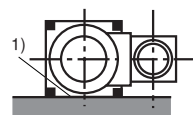

The mating connector can be brought to the desired position after the nut was loosened (see page 13)

¹⁾ Valve contact face
(O-ring recesses in the housing)

Component series 20 to 29 = **2X**
(20 to 29: unchanged installation and connection dimensions)

Pressure rating

Up to 50 bar = **50**
Up to 100 bar = **100**
Up to 200 bar = **200**
Up to 315 bar = **315**

Accessories (not included in scope of supply)

- Sandwich plate with X and Y port
(for details, see page 3)
Type HSZ 10 B097-3X/M01
Material no.: **R900320785**
- Subplates to data sheet RE 45054
 - G 535/01 (G3/4), Material no. **R900476061**
 - G 536/01 (G1), Material no. **R900476059**
- External control for type ZDRE:
 - Analog amplifier VT-MSPA1-11-1X/V0 of modular design to data sheet RE 30223
 - Digital amplifier VT-VSPD-1-2X/V0/-0-1 of Euro-card format to data sheet RE 30523
 - Analog amplifier VT-VSPA1-11-1X/V0/0 of Euro-card format to data sheet RE 30100
- Mating connectors (for details, see page 8)
 - For ZDRE: to DIN EN 175301-803, Material no. **R901017011**
 - For ZDRE: to DIN EN 175201-804, Material no. **R900021267** or **R900223890**

Further details in clear text

Seal material

M = NBR seals,

V = FKM seals

Electronics interface

A1 = Command value 0 to 10 V

F1 = Command value 4 to 20 mA

No code = For ZDRE

Electrical connection for ZDRE

K4 = **Without** mating connector, with component plug to DIN EN 175301-803

K31 = **Without** mating connector, with component plug to DIN EN 175201-804

Supply voltage of control electronics

G24 = DC voltage 24 V

M = Without check valve

Pilot oil supply/drain

Y = Pilot oil supply for directional valve from port P2, external pilot oil drain for directional valve and ZDRE

XY = External pilot oil supply for directional valve, external pilot oil drain for directional valve and ZDRE

L = Pilot oil supply for directional valve from P2, internal pilot oil drain for directional valve and external for ZDRE

XL = Pilot oil supply from P2 to X is plugged (direct operated directional valve needs **no** pilot oil), pilot oil drain of directional valve is plugged (direct operated directional valve needs **no** pilot oil drain), external pilot oil drain for ZDRE

Note: If no pilot oil supply is provided on the subplate, use sandwich plate HSZ 10 B097-3X/M01 for the supply.

Symbols (① = component side, ② = plate side)

Type ZDRE

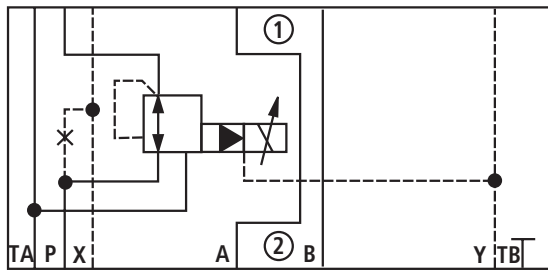

Type ZDRE10VP...XY

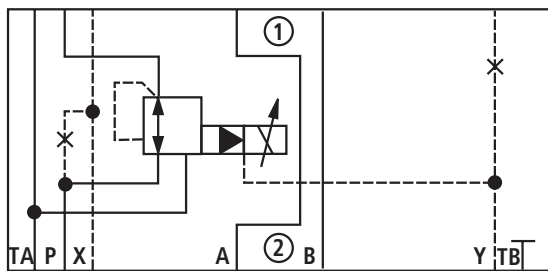

Type ZDRE10VP...XL

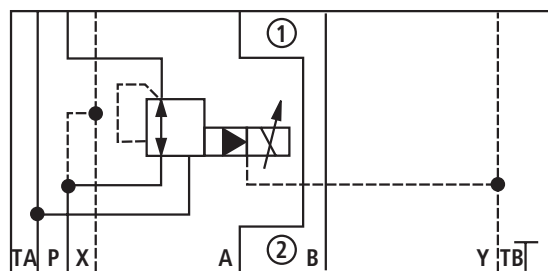

Type ZDRE10VP...Y

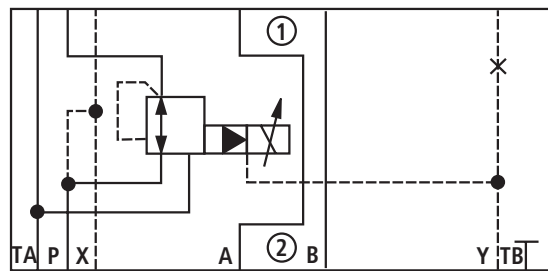

Type ZDRE10VP...L

Type ZDREE

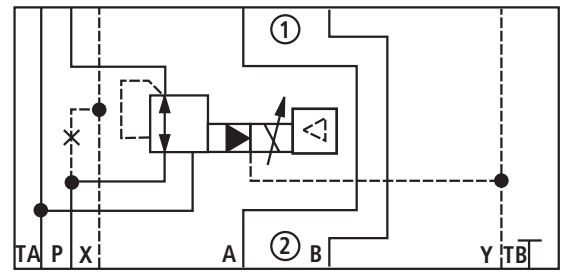

Type ZDREE10VP...XY

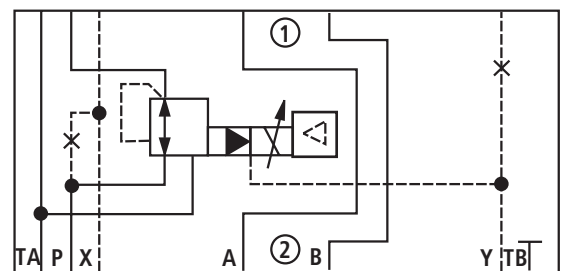

Type ZDREE10VP...XL

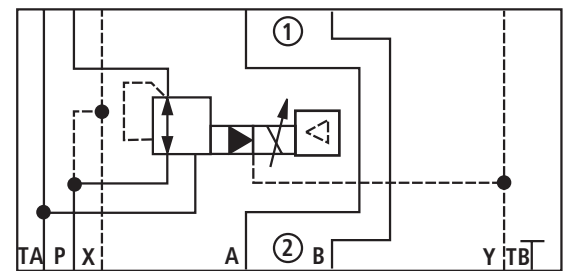

Type ZDREE10VP...Y

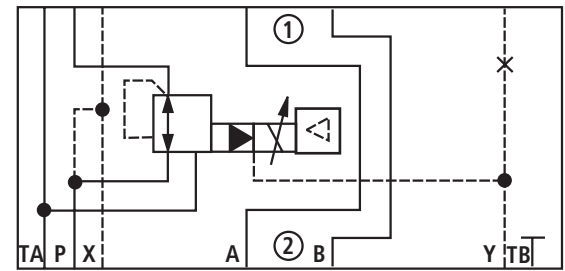

Type ZDREE10VP...L

Type sandwich plate HSZ

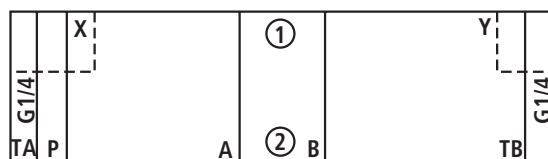

Sandwich plate HSZ 10 B097-3X/M01

- Dimensions (length x width x height): 100 x 70 x 30 mm
- Weight: 2.5 kg
- Size of ports X and Y: G1/4
- Dimensional sheet no.: R900262648

Function, section

Type ZDRE

Valves of type ZDRE... are pilot operated pressure reducing valves of sandwich plate design in 3-way variant, i.e. with pressure limitation of the actuator pressure.

They are used for reducing a system pressure.

They basically consist of pilot part (1) with proportional solenoid (2), main valve (3) and control spool (4). The pressure in channel P1 is adjusted in dependence on the command value via proportional solenoid (2).

In the rest position, i.e. when no pressure is present in channel P2, control spool (4) opens the connection from channel P2 to P1.

The pressure in channel P1 acts via bore (5) onto spool area (6). The pilot oil for the pilot valve is taken from channel P1 and flows via bore (5), orifice (7), to spring chamber (8). From there, it is fed via valve seat (9), bore (10) and Y-line back to the tank.

The pressure required in channel P1 is pre-selected on the associated amplifier. The proportional solenoid moves valve poppet (11) towards valve seat (9) and increases the pressure in spring chamber (8). Thus, the pressure in both chambers (6) and (8) is balanced, and compression spring (12) pushes spool (4) to the right in the opening direction P2 to P1. As soon as actuator pressure P1 has increased to the value set on the pilot valve, valve poppet (11) opens and limits the pressure in spring chamber (8). Control spool (4) now moves to the left to the control position. When actuator pressure P1 exceeds the value set on the pilot valve, the control spool is pushed further to the left. It closes the connection from P2 to P1 and opens the connection P1 to tank TA1 at control land (13) until this pressure falls again to the set value.

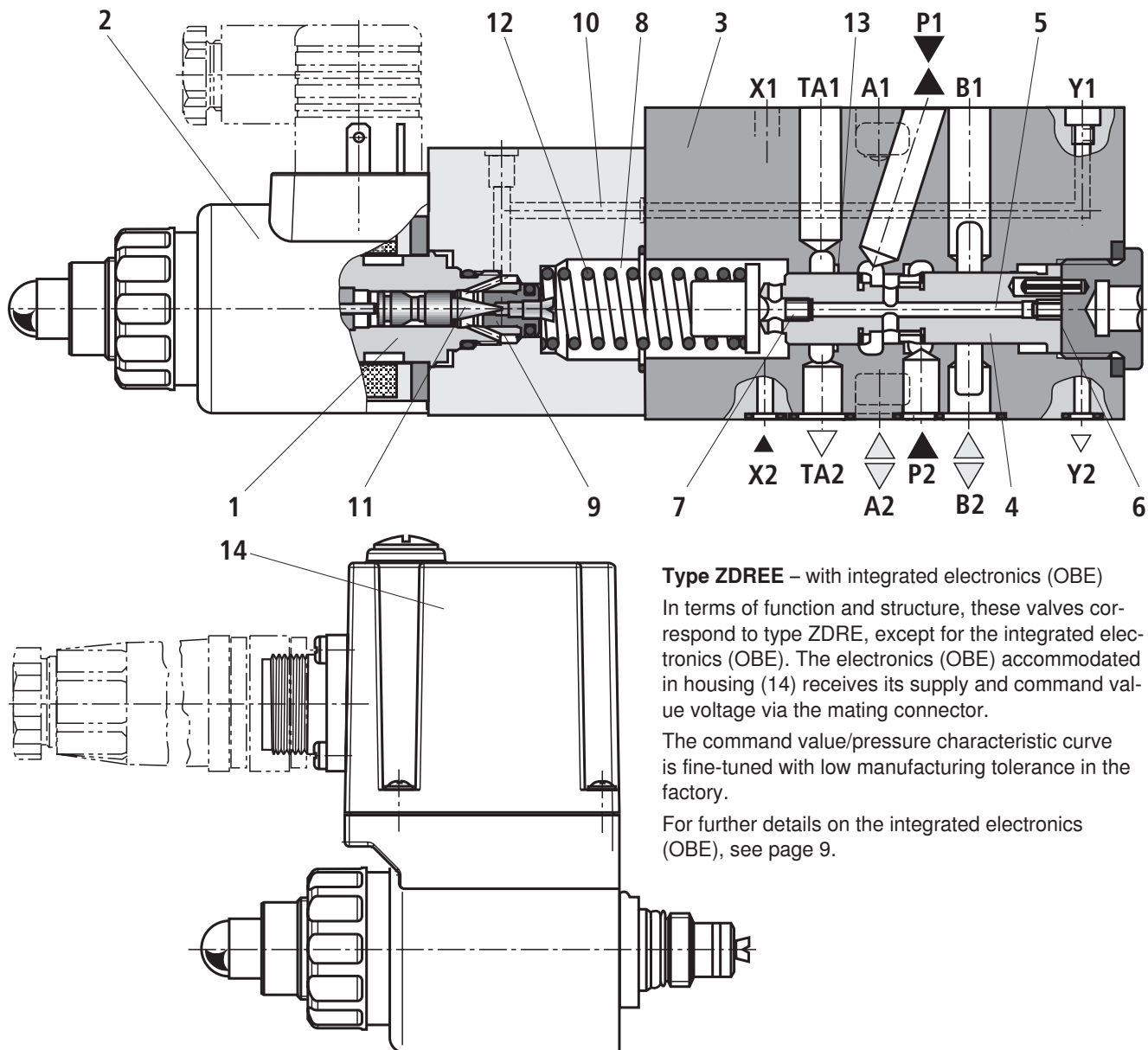

Type ZDREE – with integrated electronics (OBE)

In terms of function and structure, these valves correspond to type ZDRE, except for the integrated electronics (OBE). The electronics (OBE) accommodated in housing (14) receives its supply and command value voltage via the mating connector.

The command value/pressure characteristic curve is fine-tuned with low manufacturing tolerance in the factory.

For further details on the integrated electronics (OBE), see page 9.

Pilot oil supply for directional valve mounted above

Notes

– On the **direct operated** directional valve, the seals for ports X and Y are missing on the connection faces of the housing. To prevent hydraulic fluid from flowing out, the pilot oil supply from P2 to X and the pilot oil drain between the directional valve and the ZDRE(E) must be plugged (variant XL).

– Leakage through the spool clearance from P to B can result in pressure building up in channel B!
 – A **pilot operated** proportional directional valve in conjunction with the ZDRE(E) must have an **external pilot oil supply**.

On variants XY and XL the connection between P2 and X is plugged.

On variants Y and L port X must be plugged on the subplate.

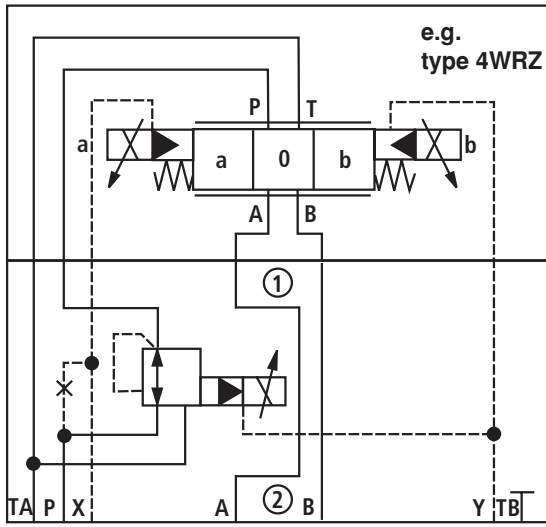

Type ZDRE(E) 10...2X/...XY

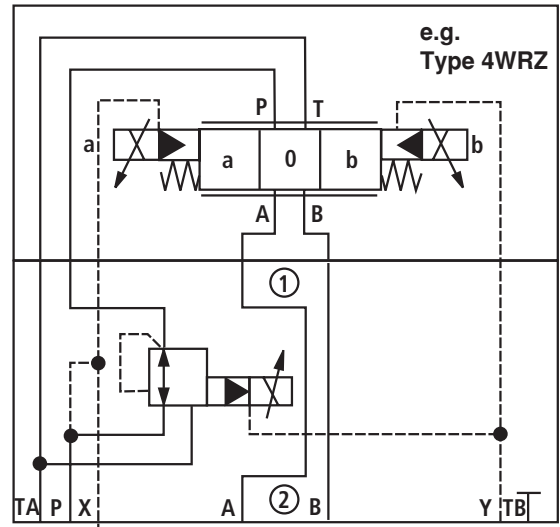

Type ZDRE(E) 10...2X/...Y

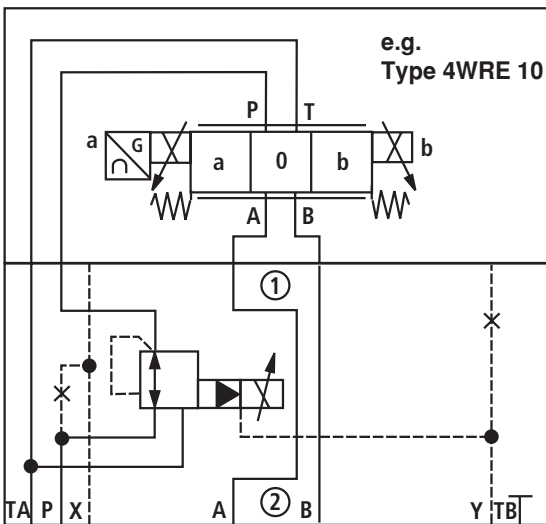

Type ZDRE(E) 10...2X/...XL

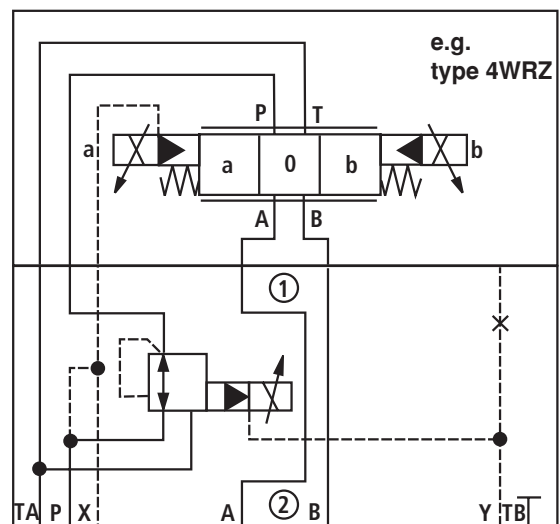

Type ZDRE(E) 10...2X/...L

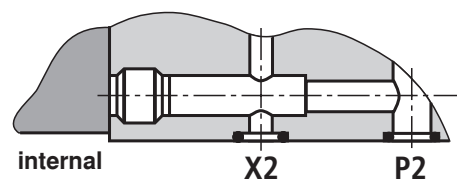
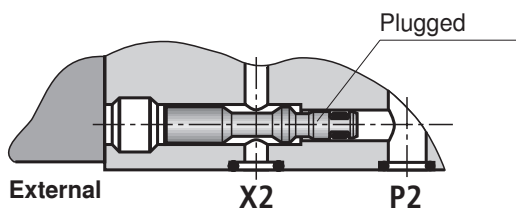

Technical data (for applications outside these parameters, please consult us!)**General**

Weight	ZDRE	kg	5.1
	ZDREE	kg	5.2
Installation orientation			Preferred orientation of the proportional solenoid: pointing downwards or horizontal
Storage temperature range		°C	-20 to +80
Ambient temperature range	ZDRE	°C	-20 to +70
	ZDREE	°C	-20 to +50

Hydraulic (measured with HLP 46; $\vartheta_{\text{oil}} = 40 \text{ °C} \pm 5 \text{ °C}$)

Maximum operating pressure	Port P1	bar	315	The pressure in an P2 must be about 20 bar higher than the required set pressure, which is to be achieved in P1.
	Ports P2; A; B; X	bar	350	
	Port T	bar	250	
	Port Y or L		Line separately and at zero pressure to tank	
Maximum set pressure in port P1	Pressure rating 50 bar	bar	50	
	Pressure rating 100 bar	bar	100	
	Pressure rating 200 bar	bar	200	
	Pressure rating 315 bar	bar	315	
Min. set pressure in channel P1 with zero command value		bar	See $p_{E \text{ min}}-q_v$ characteristic curve on page 12	
Permissible max. flow		l/min	80	
Pilot flow		l/min	0.6 to 0.9	
Hydraulic fluid			Mineral oil (HL, HLP) to DIN 51524, further hydraulic fluids on request	
Hydraulic fluid temperature range		°C	-20 to +80	
Viscosity range		mm ² /s	15 to 380	
Permissible max. degree of contamination of the hydraulic fluid - cleanliness class to ISO 4406 (c)			Class 20/18/15 ¹⁾	
Hysteresis		%	±3 of maximum set pressure	
Repeatability		%	< ±2 of maximum set pressure	
Linearity		%	±3.5 of maximum set pressure	
Manufacturing tolerance of command value/pressure characteristic curve, referred to hysteresis characteristic curve	ZDRE ²⁾	%	±5 of set max. pressure	
	ZDREE ³⁾	%	±1.5 of set max. pressure	
Step response $T_u + T_g$	10 → 90%	ms	~160	Measured with 5 liters of a standing hydraulic fluid column in port P1
	90 → 10%	ms	~160	

¹⁾ The cleanliness classes specified for components must be adhered to in hydraulic systems. Effective filtration prevents malfunction and, at the same time, prolongs the service life of components.

For the selection of filters, see data sheets RE 50070, RE 50076, RE 50081, RE 50086 and RE 50088.

²⁾ For details, see page 10

³⁾ Adjustment in the factory

Technical data (for applications outside these parameters, please consult us!)**Electrical**

Minimum solenoid current		mA	100
Maximum solenoid current		mA	1600 ± 10 %
Solenoid coil resistance	Cold value at 20 °C	Ω	5.5
	Max. warm value	Ω	8.05
Duty cycle		%	100

Electrical, integrated electronics (OBE)

Supply voltage	Nominal voltage	VDC	24
	Lower limit value	VDC	21
	Upper limit value	VDC	35
Current consumption		A	≤ 1.5
Required fuses		A	2, slow-blowing
Inputs	Voltage	V	0 to 10
	Current	mA	4 to 20
Output	Actual current value	mV	1 mV Δ 1 mA
Type of protection of the valve to EN 60529			IP 65 with mating connector mounted and locked

Electrical connection (dimensions in mm)

ZDRE

Connection to component plug

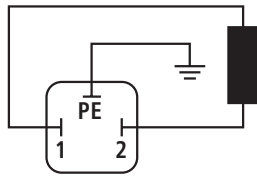

Connection to mating connector

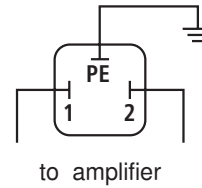

Mating connector (black) to DIN EN 175301-803
Material no. **R901017011**
(separate order)

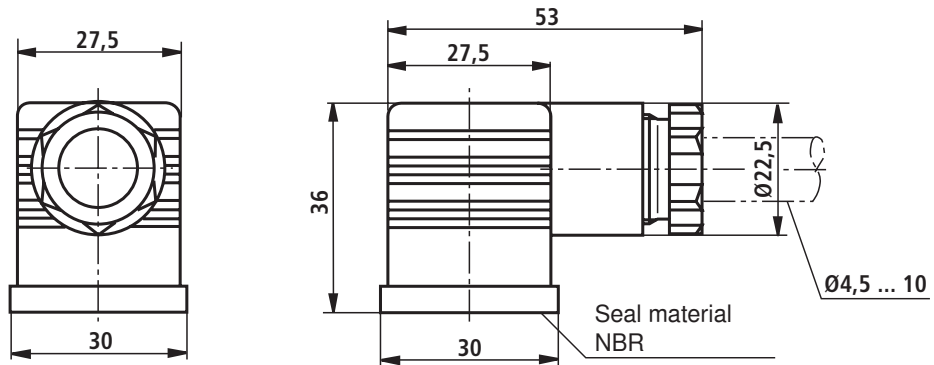

ZDREE

Component plug pinout	Contact	Pinout of interface "A1"	Pinout of interface "F1"
Supply voltage	A	24 VDC ($u(t) = 21 \text{ V to } 35 \text{ V}$); $I_{\text{max}} \leq 1.5 \text{ A}$	
	B	0 V	
Actual value reference potential	C	Reference contact F; 0 V	Reference contact F; 0 V
Differential amplifier input	D	0 to 10 V; $R_i = 100 \text{ k}\Omega$	4 to 20 mA; $R_i = 100 \Omega$
	E	Command value reference potential	
Measurement output (actual value)	F	0 to 1.6 V actual value ($1 \text{ mV} \triangleq 1 \text{ mA}$) Load resistance > 10 k Ω	
	PE	Connected to solenoid and valve housing	

Mating connectors to DIN EN 175201-804, soldered contacts for cable cross-section 0.5 to 1.5 mm²

Plastic variant,
Material no. **R900021267**,
(separate order)

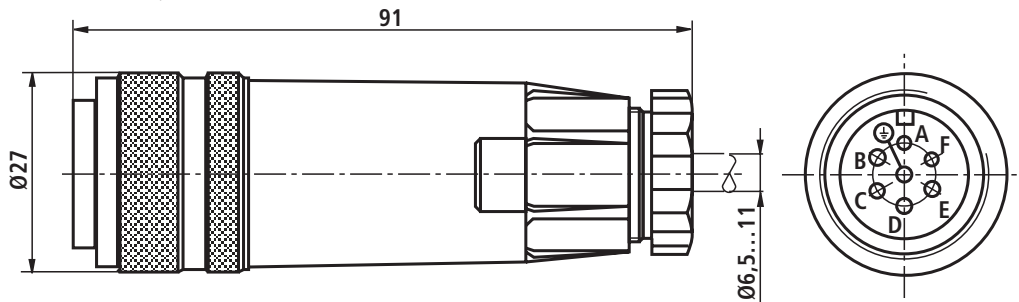

Metal variant,
Material no. **R900223890**
separate order

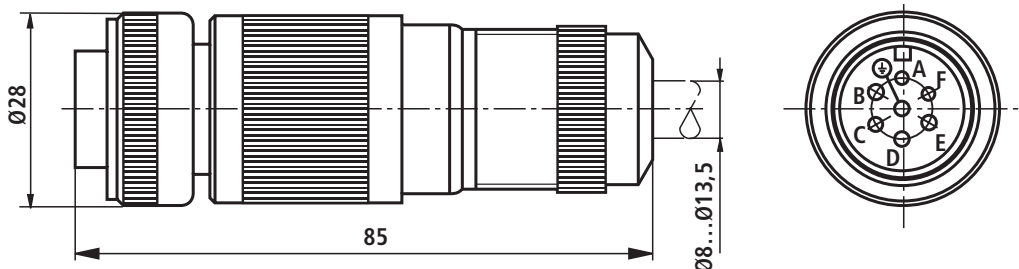

Electrical connection

Connection cable for ZDREE

- Recommendation: 6-wire, 0.75 or 1 mm² plus protective earth conductor and shield
- Connect shield only on the supply side to PE
- Permissible max. length 100 m

The minimum supply voltage on the power supply unit depends on the length of the supply cable (see diagram).

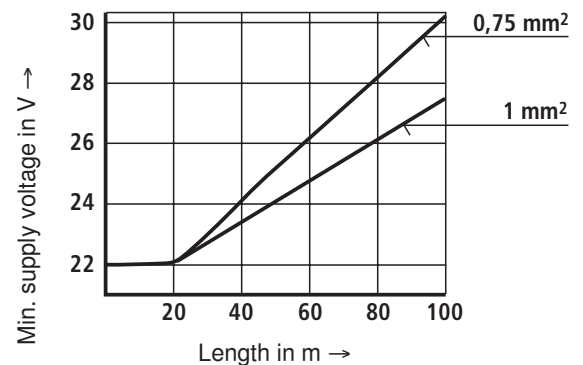

Integrated electronics (OBE) of type ZDREE

Function

Power supply to electronics via connections A and B. The command value is applied to differential amplifier connections D and E.

The characteristic curve generator adapts the command value/solenoid current characteristic curve to the valve so that non-linearities in the hydraulics are compensated for and a linear command value/pressure characteristic curve is obtained.

The current regulator regulates the solenoid current independently of the solenoid coil resistance.

A chopper amplifier with a clock frequency of ca. 180 Hz to 400 Hz forms the power output stage of the electronics for controlling the proportional solenoid. The output signal is pulse-width-modulated (PWM).

For testing the solenoid current, a voltage, which is proportional to the solenoid current, can be measured between pin F(+) and pin C(-) on the plug-in connector. **1 mV** corresponds to a solenoid current of **1 mA**.

Block circuit diagram

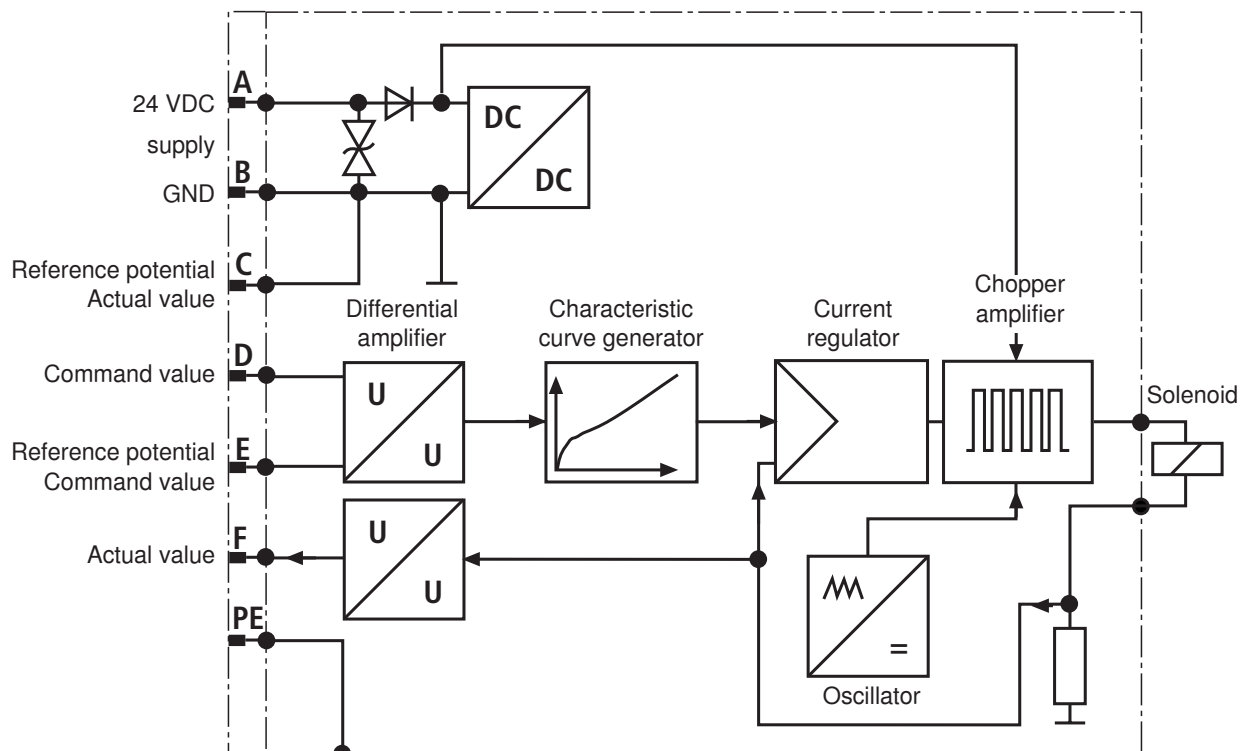

Characteristic curves (measured with HLP46, $\vartheta_{oil} = 40 \text{ }^\circ\text{C} \pm 5 \text{ }^\circ\text{C}$)

Reduced pressure in port P1 in dependence upon the command value (manufacturing tolerance)

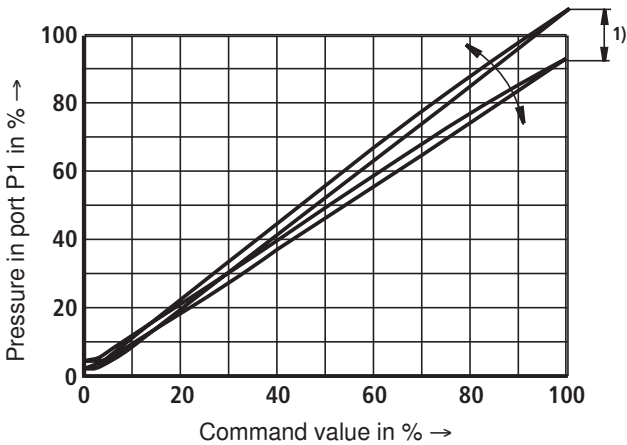

1) For valve ZDRE the tolerance can be modified on the **external amplifier** (for type and data sheet, see page 2) using command value attenuator potentiometer "Gw". The digital amplifier can be adjusted by means of parameter "Limit". Here, the control current specified in the technical data must not be exceeded. In order that several valves can be matched to the same characteristic curves, the pressure at a command value of 100 % must not be set higher than the maximum pressure setting of the pressure rating.

Pressure in port P1 in dependence upon the command value (at flow 0 l/min)

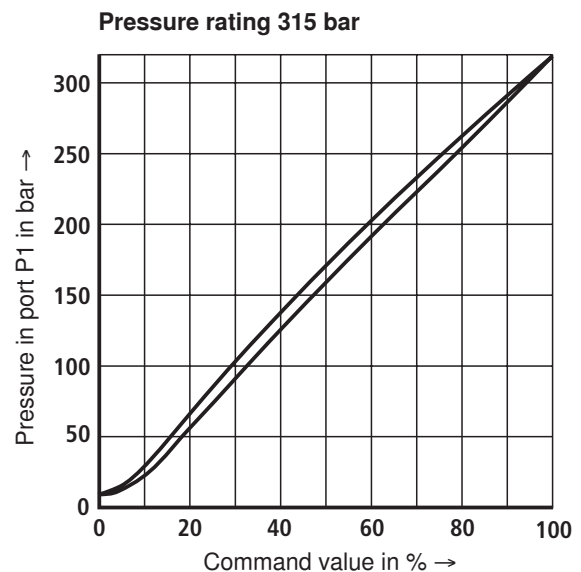
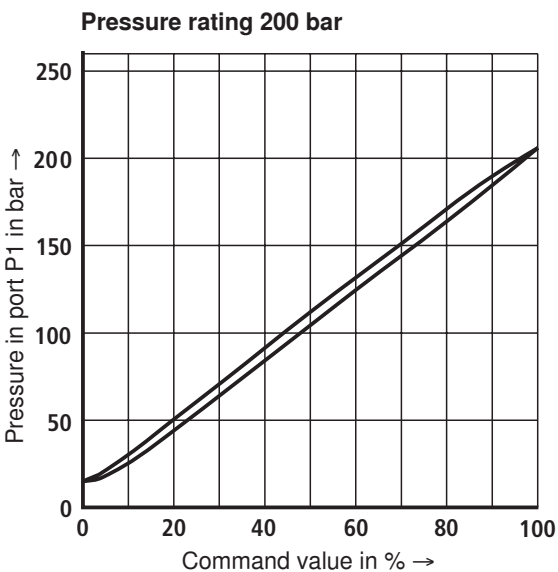
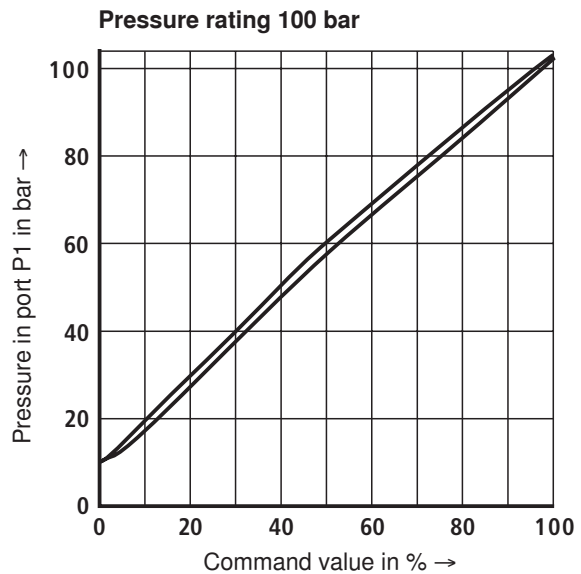
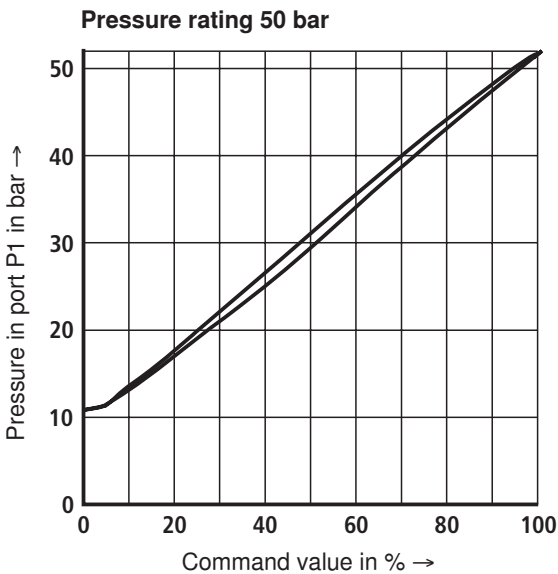

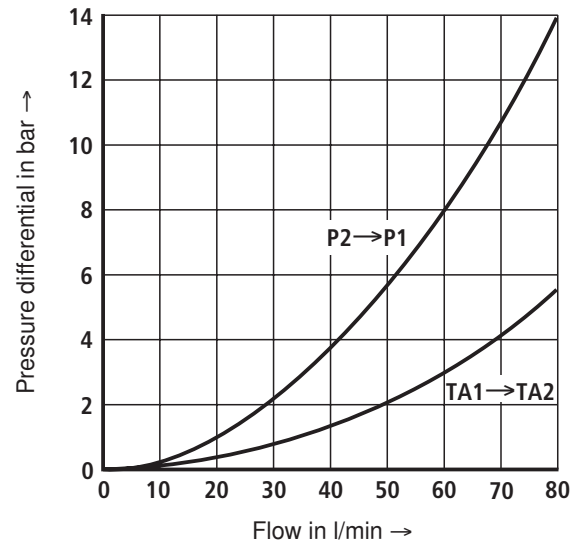
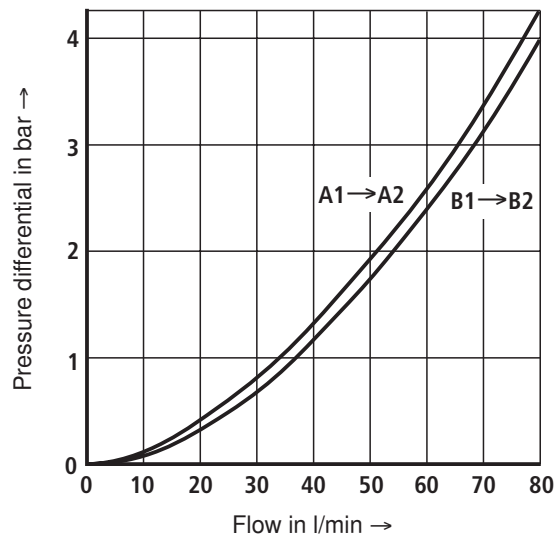
Characteristic curves (measured with HLP46, $\vartheta_{\text{oil}} = 40 \text{ °C} \pm 5 \text{ °C}$)**Pressure differential in dependence upon the flow**

Characteristic curves (measured with HLP46, $\vartheta_{oil} = 40 \text{ }^\circ\text{C} \pm 5 \text{ }^\circ\text{C}$)

Pressure in port P1 in dependence upon the flow

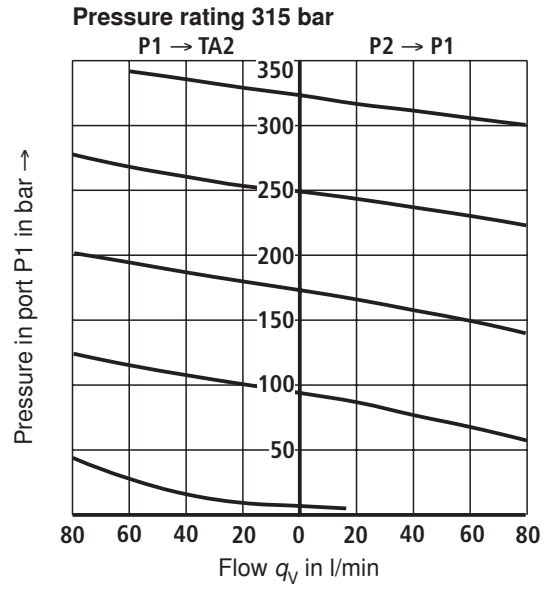
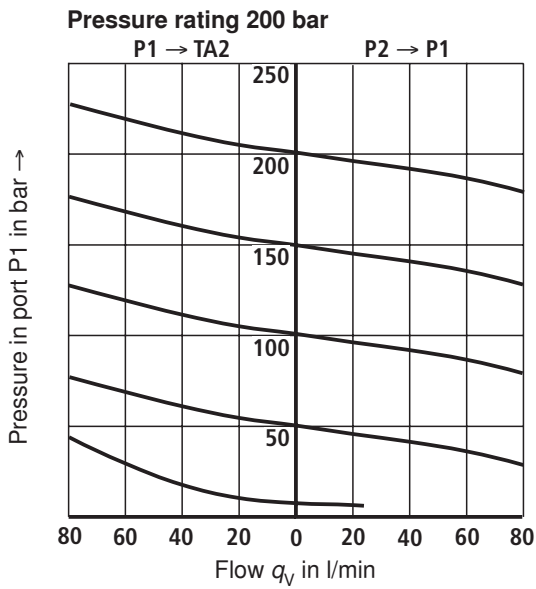
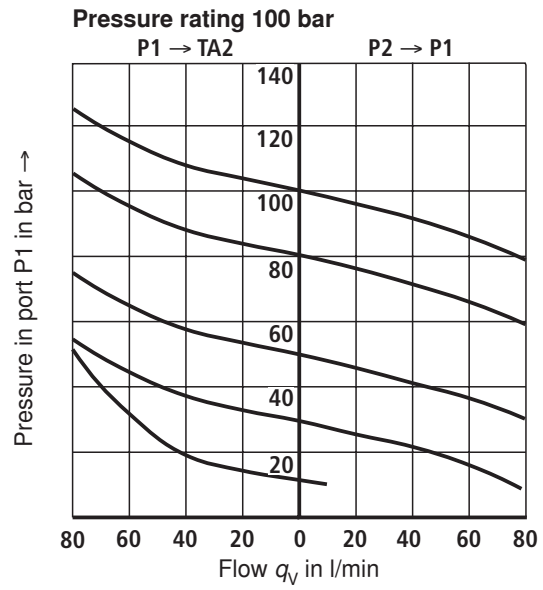
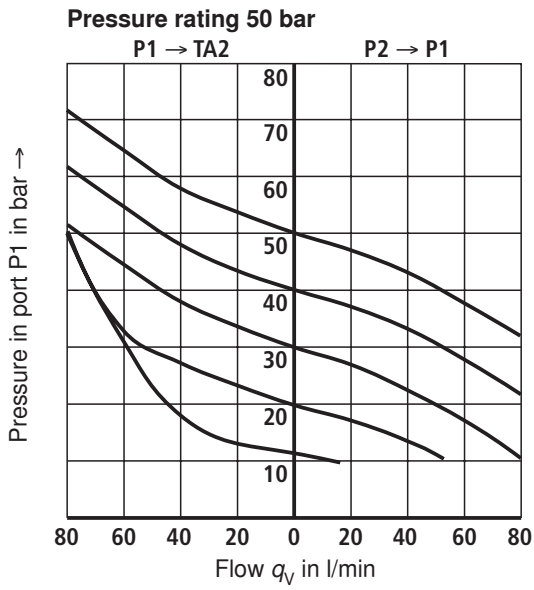

Min. set pressure in dependence upon the flow at zero command value

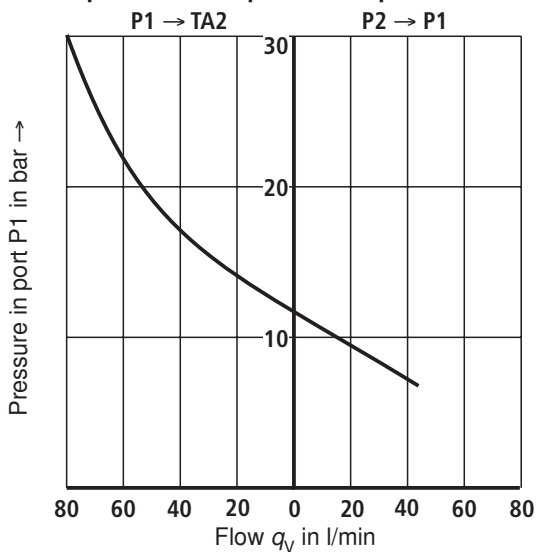

Unit dimensions (dimensions in mm)

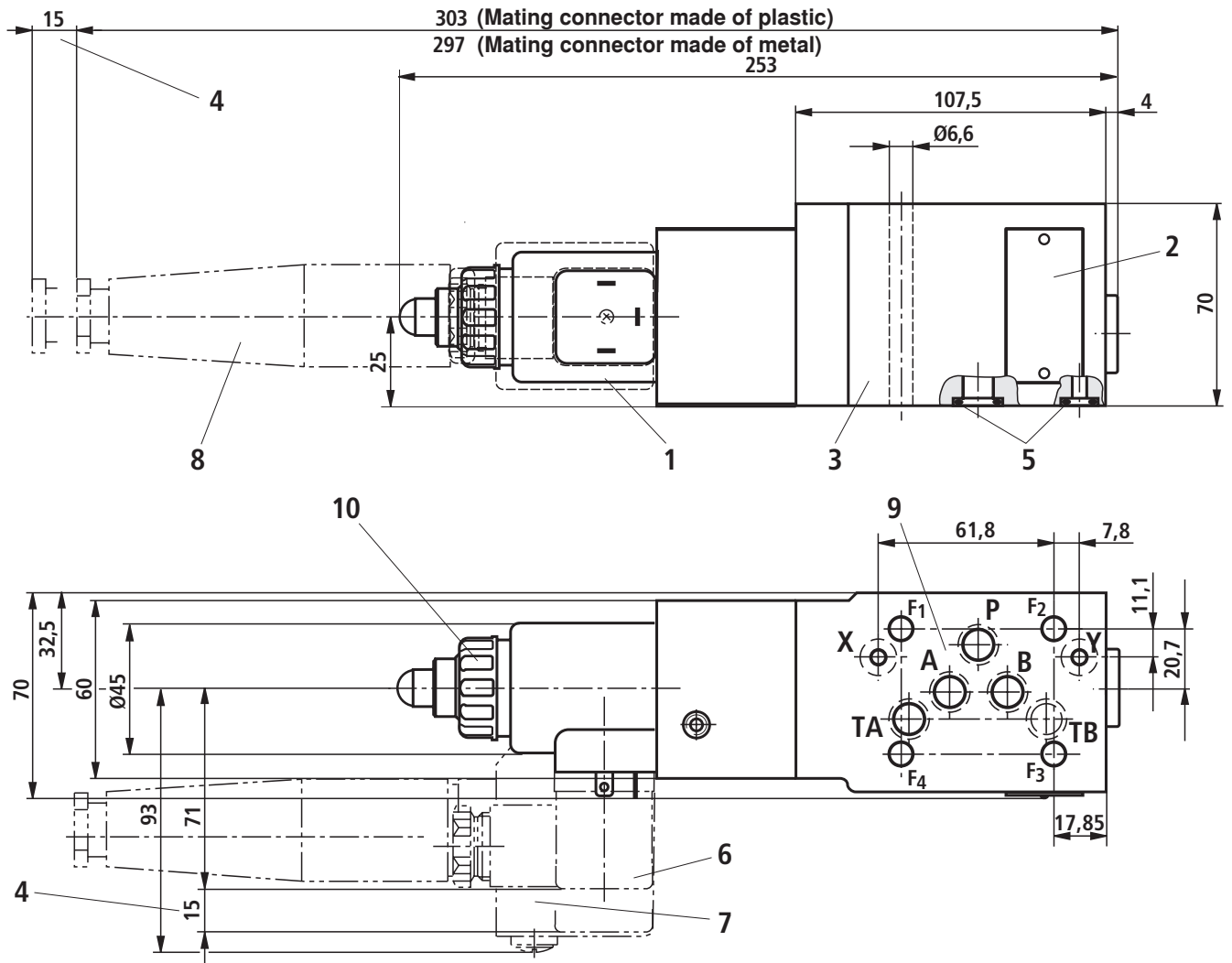

- 1 Solenoid coil
- 2 Nameplate
- 3 Valve housing
- 4 Space required to remove mating connector
- 5 Identical seal rings for ports A2, B2, P2, TA2, TB2
Identical seal rings for ports X2, Y2
- 6 Mating connector for type ZDRE
(separate order)
- 7 Integrated electronics (type ZDREE) with component plug
- 8 Mating connector for type ZDREE, plastic or metal variant, (separate order)
- 9 Porting pattern to DIN 24340-A10 and ISO 4401-05-05-0-05 (X, Y as required)
- 10 O-ring and plastic nut A/F 32 for coil mounting
The nut can be loosened by turning it counter-clockwise (1 turn). The solenoid coil can then be rotated to the desired position and fixed by tightening the nut.
Tightening torque: 4+1 Nm

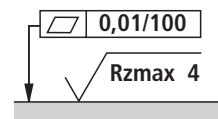

Required surface quality of valve mounting face

Valve mounting screws

4 hexagon socket head cap screws ISO 4762-M6-10.9-flZn-240h-L
(Friction coefficient $\mu_{\text{total}} = 0.09$ to 0.14);
tightening torque $M_T = 12.5 \text{ Nm} \pm 10 \%$

or

4 hexagon socket head cap screws ISO 4762-M6-10.9
(Friction coefficient $\mu_{\text{total}} = 0.12$ to 0.17);
tightening torque $M_T = 15.5 \text{ Nm} \pm 10 \%$

Screw length as required

Notes

Bosch Rexroth AG
Hydraulics
Zum Eisengießer 1
97816 Lohr am Main, Germany
Phone +49 (0) 93 52 / 18-0
Fax +49 (0) 93 52 / 18-23 58
documentation@boschrexroth.de
www.boschrexroth.de

© This document, as well as the data, specifications and other information set forth in it, are the exclusive property of Bosch Rexroth AG. It may not be reproduced or given to third parties without its consent. The data specified above only serve to describe the product. No statements concerning a certain condition or suitability for a certain application can be derived from our information. The information given does not release the user from the obligation of own judgment and verification. It must be remembered that our products are subject to a natural process of wear and aging.

Notes

Bosch Rexroth AG
Hydraulics
Zum Eisengießer 1
97816 Lohr am Main, Germany
Phone +49 (0) 93 52 / 18-0
Fax +49 (0) 93 52 / 18-23 58
documentation@boschrexroth.de
www.boschrexroth.de

© This document, as well as the data, specifications and other information set forth in it, are the exclusive property of Bosch Rexroth AG. It may not be reproduced or given to third parties without its consent. The data specified above only serve to describe the product. No statements concerning a certain condition or suitability for a certain application can be derived from our information. The information given does not release the user from the obligation of own judgment and verification. It must be remembered that our products are subject to a natural process of wear and aging.

Notes

Bosch Rexroth AG
Hydraulics
Zum Eisengießer 1
97816 Lohr am Main, Germany
Phone +49 (0) 93 52 / 18-0
Fax +49 (0) 93 52 / 18-23 58
documentation@boschrexroth.de
www.boschrexroth.de

© This document, as well as the data, specifications and other information set forth in it, are the exclusive property of Bosch Rexroth AG. It may not be reproduced or given to third parties without its consent. The data specified above only serve to describe the product. No statements concerning a certain condition or suitability for a certain application can be derived from our information. The information given does not release the user from the obligation of own judgment and verification. It must be remembered that our products are subject to a natural process of wear and aging.